

AV over IP - the next generation ProAV connectivity technology

By Mike Tsinberg - June 2018

Everybody heard up to now this new buzz AV over IP (AVoIP). This paper will cover basic technology and features associated with this new technology.

By definition, IP switch offers bi-directional data streaming on each of its RJ45 ports. Each port can be a transmitter or a receiver of data at any time. That is quite a big departure compared with traditional HDMI or HDBaseT AV switchers. In a traditional AV switch number of inputs and outputs and direction of the data flow is always fixed. These configurations are usually a factor of 2: 2x2, 4x4, 8x4, 8x8, 16x16, 24x24 and etc. Once such a switch is installed this configuration and direction of the data flow cannot be changed.

On the other hand if 48 Port IP switch is used for AV installation each of the ports can be transmitter or receiver of the data and configuration limit here is only the total number of these ports. So 48 port IP switch can create 1x47 or 47x1 matrix with any other matrix ratio XxY in between with one limitation only: X+Y is not higher than 48.

The use of each port as transmitter or receiver only controlled by number of Video ENC or DEC units connected to the IP switch. This ratio can also be changed at any time after installation by adding or removing ENC or DEC units on any of the ports. By its nature none of the ports are designated transmitters or receivers so any of the ENC and DEC can be added or removed on any of the ports. That is a remarkable flexibility that was never available with a traditional HDMI, DVI, VGA or HDBaseT AV switch.

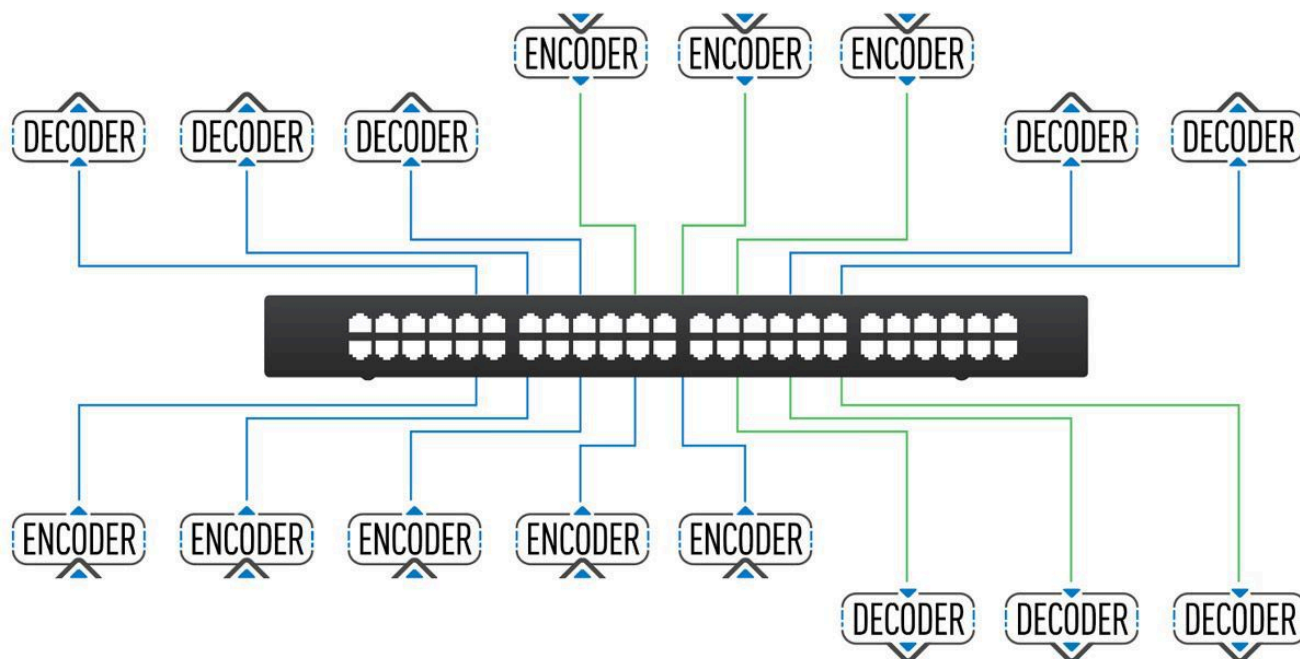

These days IP switcher is a universal data interconnection device providing connectivity for audio, video, all types of data, control, and etc. It is a very flexible system that allows connectivity regardless for the data type. In the AVOIP world we take a full advantage of that flexibility. There is nothing to prevent AVOIP ENC to include RS232, IR, USB and Audio together with Video in the transmission or reception of the data stream.

Another remarkable feature is that each data type can keep its own origination and destination address controlled only by IP addresses. So while downstream Video data packets are flying from the HDMI input of Encoder #A to the HDMI output of Decoder #B the upstream USB data flow connecting USB input ports of Decoder #C to the USB ports of Encoder #D. At the same time RS232 data may travel downstream from Encoder #E to the RS232 terminals of Decoder #F and so on.

The control data (RS232, IR) reflects IP switch overall topology and can go any direction between any ports assuming each port has its own IP address. The Video and Audio data are a bit more rigid and always flow from the Encoder to the Decoder. The reason is that more cost effective IC solution forces to have dedicated Encoders and Decoders IC's for Video and Audio compression and decompression. However, in the ProAV world that is not a limitation because Video and Audio equipment is always divided to Sources and Displays. Source always requires an Encoder while Display always requires a Decoder.

The control equipment such as Control System Master Controller can be connected at ANY (Decoder or Encoder) RS232/IR port of the system and retrieved from any other port on that network because its circuitry does not perform dedicated encoding or decoding functions. That is as also a remarkable flexibility that was never available with a traditional HDMI or HDBaseT AV switch.

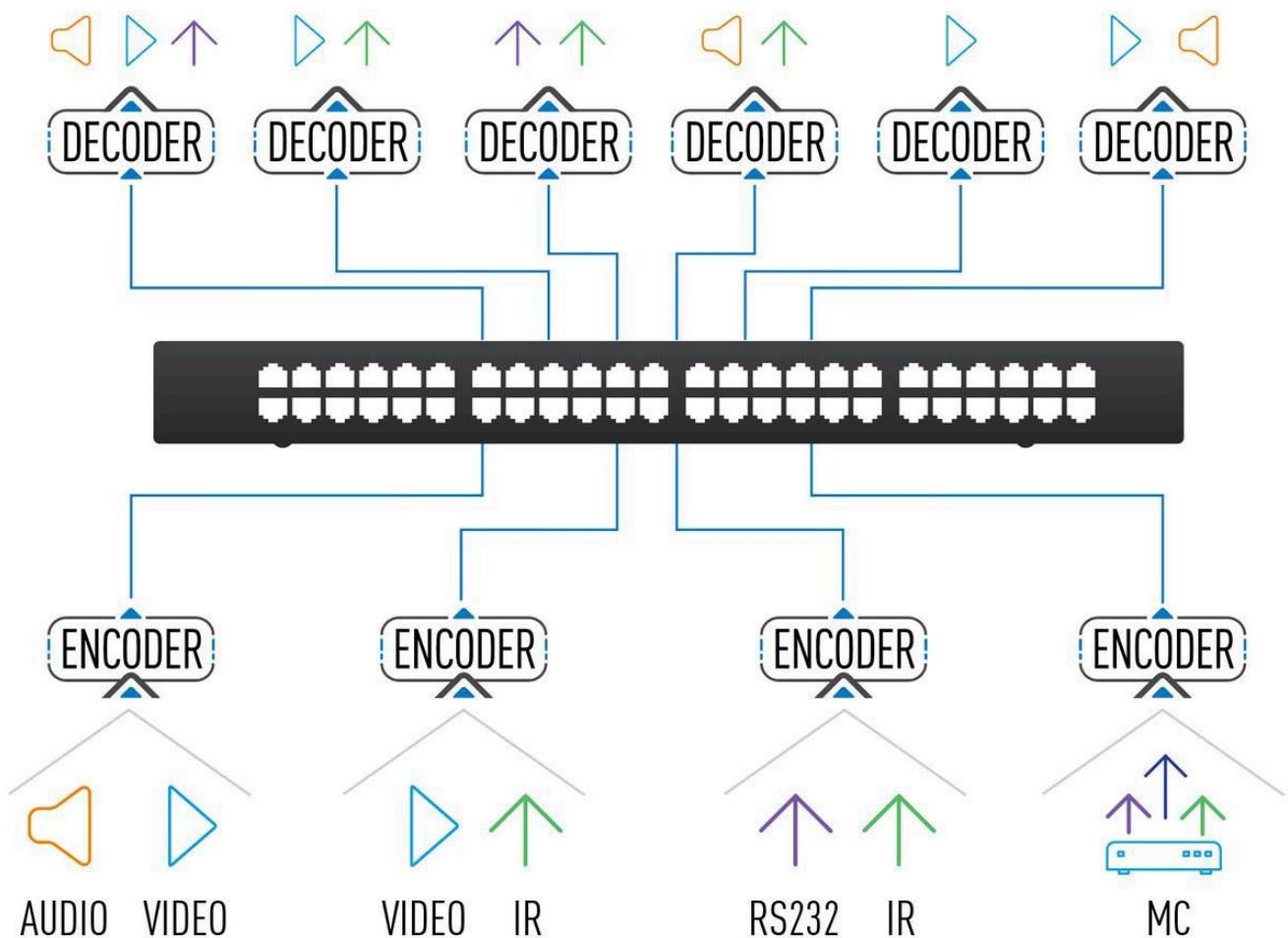

AVOIP being a fully standard IP interconnection technology can take a full advantage of POE. Standard POE is 48V technology with a lot of commoditized technology available on all levels of the products manufacturing: modules, IC, IP switchers, Injectors, separators and etc. The AVOIP Encoder or Decoder average power consumption is ~10W. So, 48 port IP switch has to be able to supply at least 480W of POE power. That is especially handy for the DEC unit that are usually located between TV monitor and the wall and have a limited access to the power. Sometimes ENC are also mounted inside the Conference room and can also benefit from the access to POE switch. This was never available in pure HDMI system and now increasingly popular in HDBaseT.

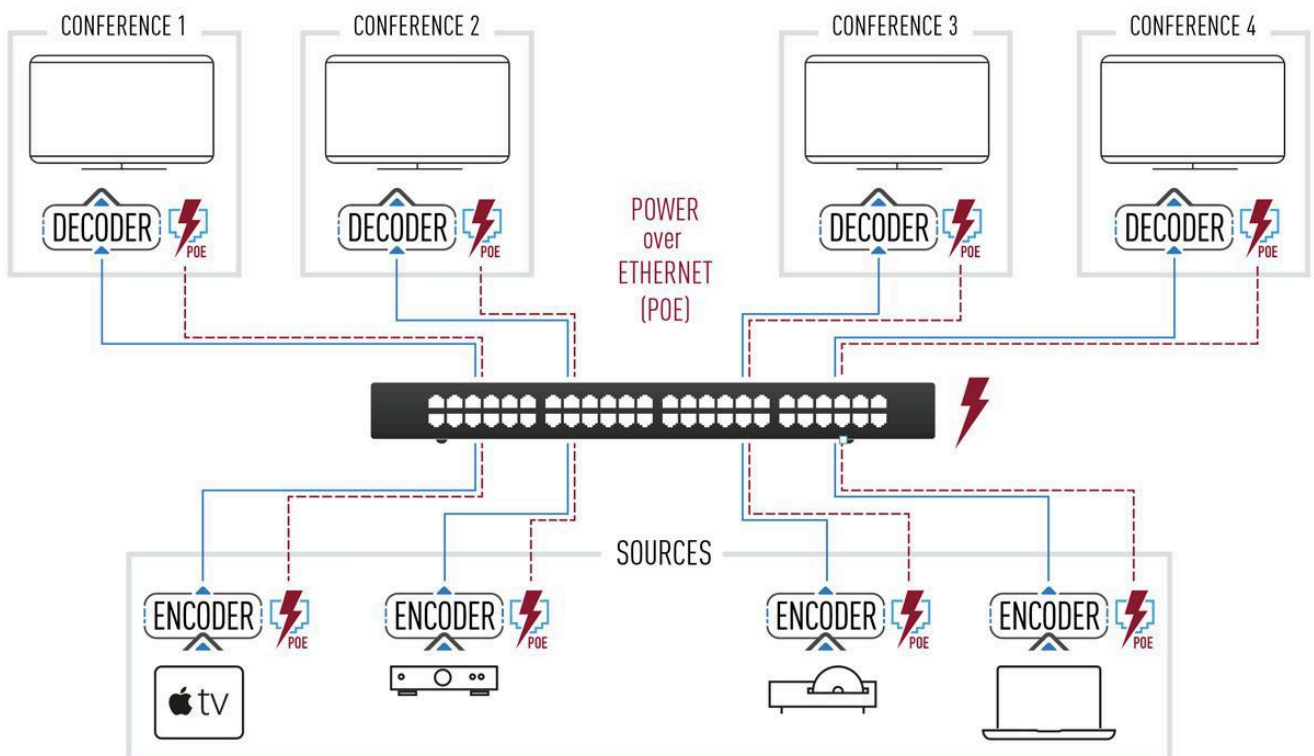

There is one disadvantage of AVOIP compare to HDMI or HDBaseT – the video portion has to be always compressed. The reasons are simple: current IP switchers most popular specifications are 1 Gbps data rate capability per any I/O port. Two most popular uncompressed video formats in the best video related configurations have following data rate requirements:

1. 1080p, 60 fps, 4:2:2, 10 bit per color requires 2.5 Gbps,
2. 4K UHD, 60 fps, 4:2:2, 10 bit per color requires 10 Gbps

There are IP switchers available with 10Gbps per port capability but they are much more expensive and represent significant difficulty to build large matrix systems.

At present there are two basic compressions systems that are used for AVOIP systems. The basic technology involved in both of them is described here: </resources/tech/knowledge-center/h264-mpeg-in-proav>

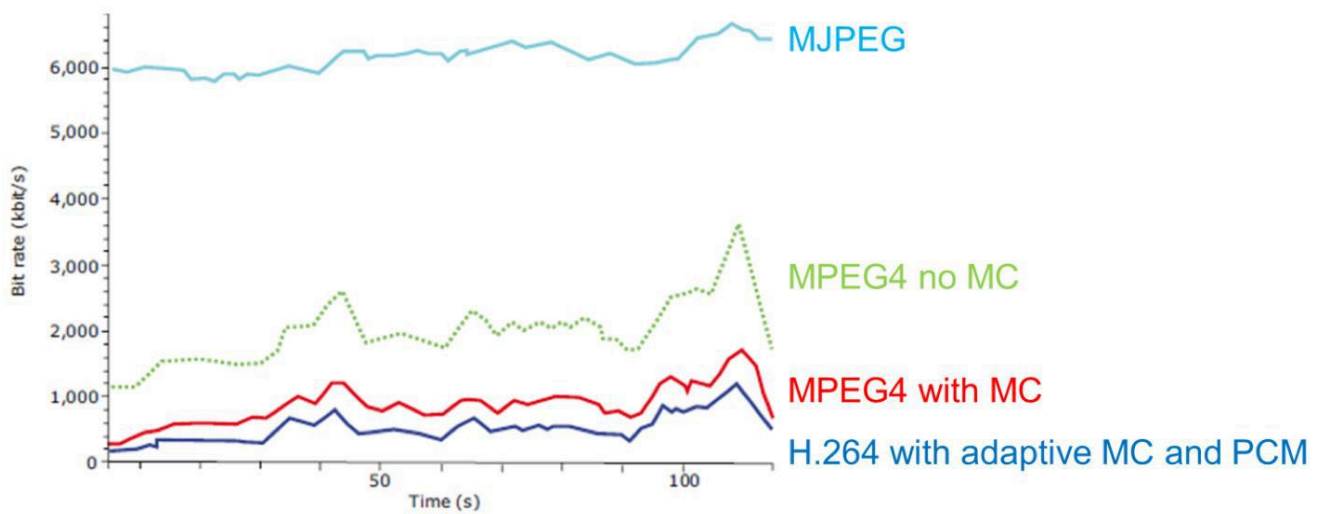

As it applies to AVOIP these compressions technologies split into two basic categories:

1. **High Compression H.264/265.** This system is able to compress incoming Video by factor of 180 or better. As a result the 1080p video can be compressed to 16 Mbps or less. Respectively the 4K video can be compressed to 60 Mbps or less. These are very beneficial rates for any IP switch. It will save a lot of money and allow construction of a very large matrix systems such as 256x256 or larger. However, such high rate of compression is achieved by using information spread between 15 frames or more and decoded video can be 200ms to 500ms behind original video time base. Some applications that must show original and processed by compression video will create out of sync experience. Such example can be a music or lecture stage in a large venue with live performance (no delay) and video monitors extending far back the hall. If this system utilize H.264/265 the extended Video monitors will be ~0.5 sec behind real time and that delay is very visible.
2. **Medium Compression JPEG2000 or variant thereof.** This system is able to compress incoming Video by factor of 10 or better. As a result the 1080p video can be compressed to 180 Mbps or less. Respectively the 4K video can be compressed to 900 Mbps or less. These are reasonable rates for current IP switch – below 1 Gbps per port. It will allow to create reasonably large matrix systems such as 40x96 or larger. Since all compression processing is achieved within one video frame timing – the overall delay will not exceed 17ms which is a way below any human sensitivity for video or audio delay. Both processed and original video and audio display may be located inside same room without any problem to the viewer. Since all delay processing is essentially fixed to no more than one frame additional image processing features such as Video Wall are also possible.

Video Wall Example use of AV over IP (Key Digital® Enterprise AV™ over IP System:

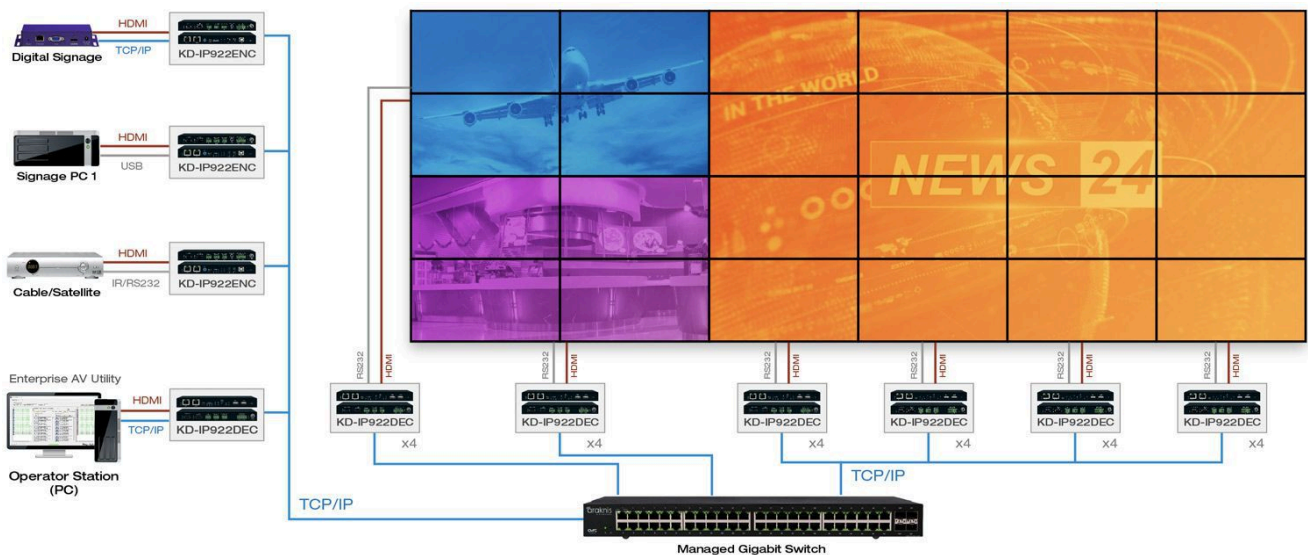

It's easy to get used to good things... IP switches are available in one unit switchers up to 48 ports. But what if you need a matrix larger than 48 Encoders and Decoders? IP switchers can be stoked up to create larger configurations. The key point here is transferred data rate between switchers. For example let's say we need 48x48 matrix per Picture 1.

Picture 1:

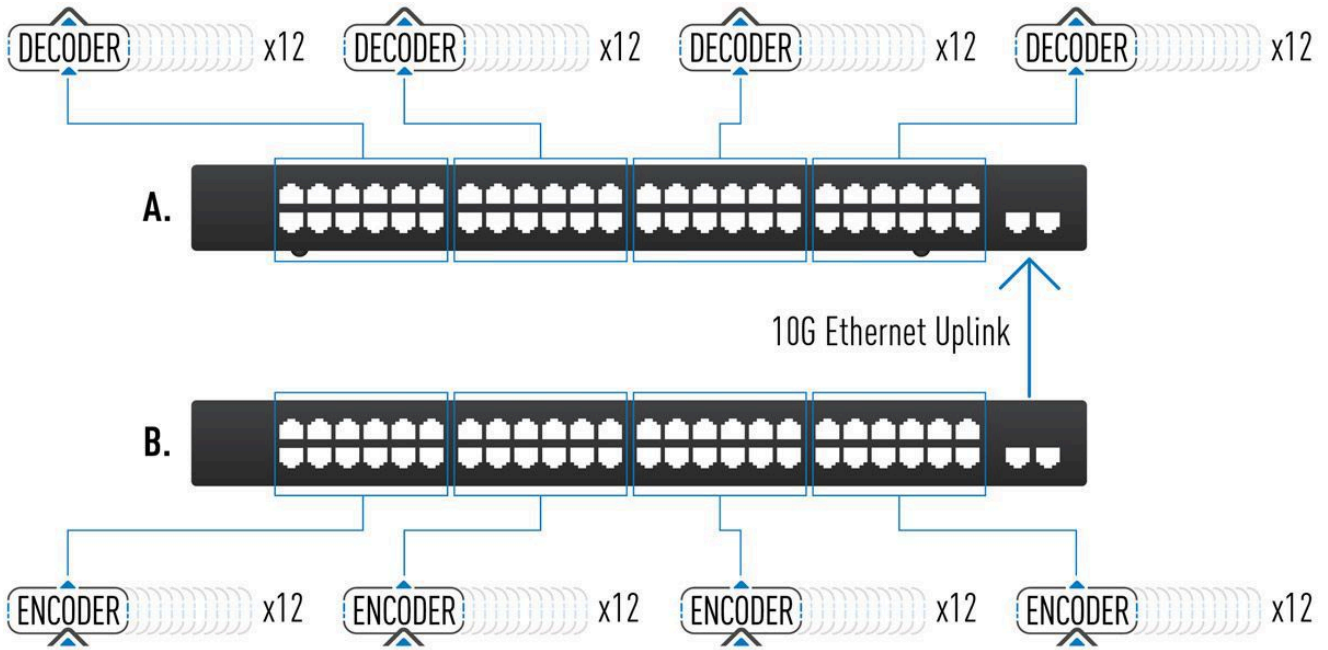

All Video Encoders are connected to switch B and all Video Decoders are connected to switch A. Naturally all Data Flow between switchers in this example goes from Switch B to switch A. If all video sources are 4K UHD and compression system used is a variant of JPEG2000 the Data Flow rate should be comfortably $900\text{Mbps} \times 48 = 43.2\text{ Gbps}$.

Not all switchers will have that capability. Most often the SFP extensions slots are around 2 Gbps or 10 Gbps each. Also most often there only two of them available. So in case of 10 Gbps SFP and four of them only 40 Gbps transfer rate available. No enough for this particular application. You would have to lower the number of Encoders to 40 and your maximum size matrix will be 40x48.

On the other hand, if you choose H.264/265 compression and 1080p video resolution the transfer data rate demand for this system will be only $16\text{ Mbps} \times 48 = 0.770\text{ Gbps}$. Even one 1 Gbps SFP port can handle it. The system can be easily extended to a very large system. Of course H. 264/265 comes with high latency and limited amount of video processing features such as Video Wall. In designing large AVOIP systems integrator need to answer a few basic questions:

1. How large is the system?
2. Does installation will feature displayed processed and unprocessed Video and Audio (latency problem)?
3. What is the video resolution required? For example if 48x48 system above uses JPEG2000 variant and 1080p video resolution - the required transfer bandwidth is 8.7 Gbps that is very manageable by variety of different switchers.

Expansion Example for a 48x96 AVOIP System:

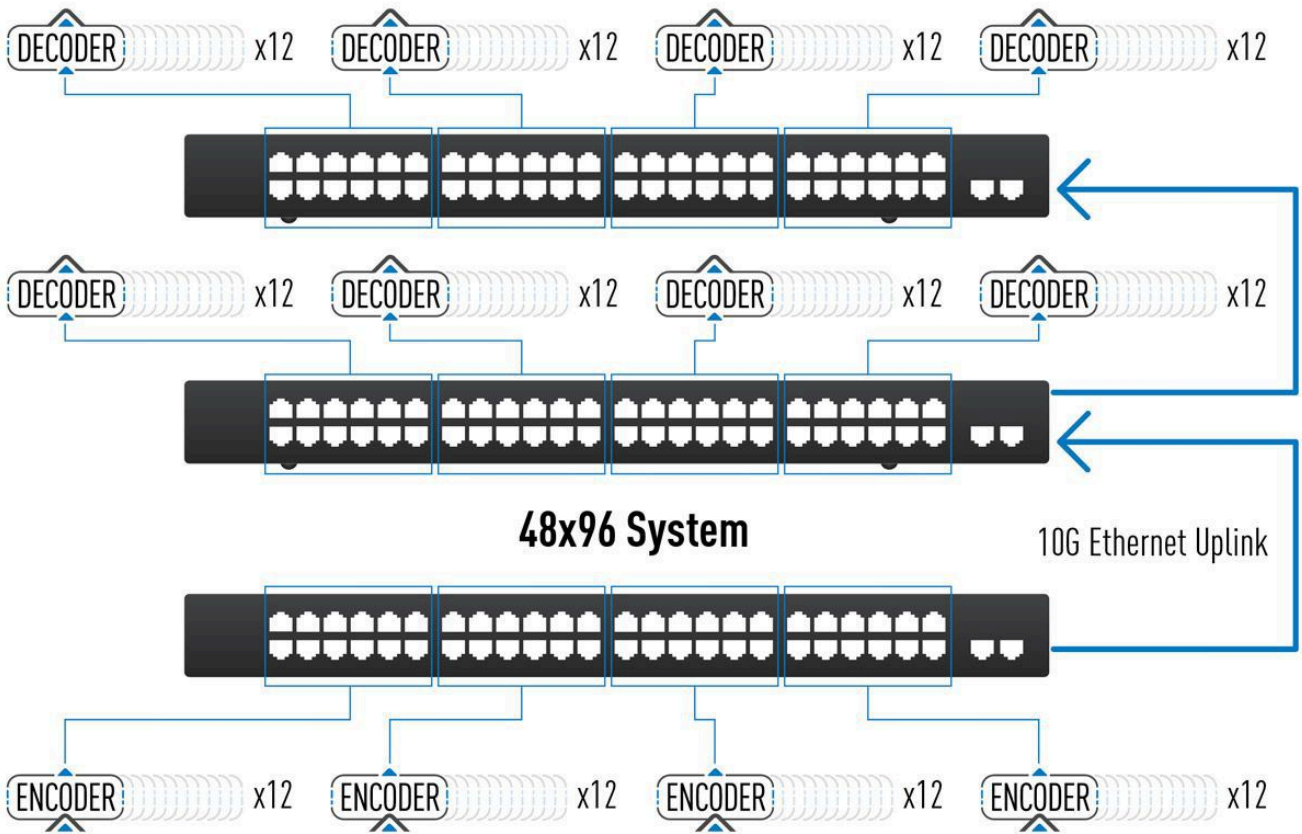

AVOIP system will follow all generic IT/IP cable recommendations. Usually they are not to exceed 330 feet from source or sink to the switch and from the switch. That is comparable with state of the art HDBaseT cable length capabilities. If longer than 330 feet is needed, there are a few standard IT technologies available: fiber or coaxial. The length can be also doubled by utilizing IP switch as a repeater between ENC and DEC effectively doubling connection length to 660 feet for twisted pair cable.

Example AVOIP System used for Extension:

