

KD-VW4x4ProK

4K UHD 4 input 4 output video wall processor and seamless matrix switcher, includes 4 Rx units. Features 5 video wall modes, independent AV routing, mirrored HDMI and UHDoTP outputs.

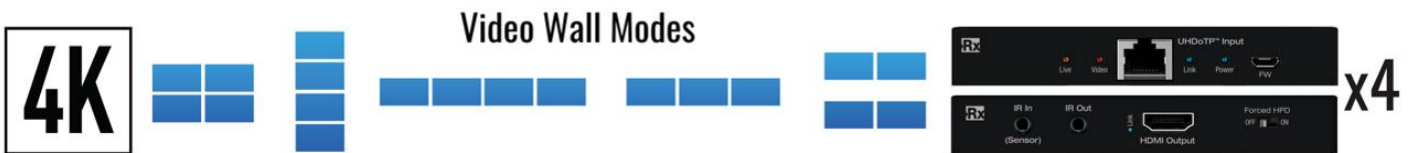

Key digital
Engineered for Your Success™

Table of Contents

About KD-VW4X4PROK	3
Quick Setup Guide	5
Connect	5
Configure	5
Control	7
Application Example	11
KD-VW4x4ProK Connections and LEDs	11
KD-EXMLVRx Connections and LEDs	11
Front Panel Control & LCD	17
IR Remote Control	18
Web User Interface	19
Video Wall Modes	21
Panel Flip	24
Bezel Control	25
Text Overlay	26
TCP/IP and RS-232 Commands	27
Integrating with AV over IP Systems	32
Specifications	33
Warranty Information	34
Product Warnings & Safety Instructions	34



Operation Manual

Please visit www.keydigital.com for the latest product documentation, firmware, control drivers and software downloads. Product features and specifications are subject to change without notice

Always follow the instructions provided in this Operating Manual.

About KD-VW4x4ProK

Key Digital's KD-VW4x4ProK is a 4 HDMI input with 4 HDMI + 4 UHDoTP mirrored output video wall processor and seamless matrix switcher with independent audio routing.

KD-VW4x4ProK is perfect for video wall and large format viewing applications like Bar & Restaurant, Sports & Gaming Caves, Digital Signage, House of Worship, Entertainment Centers, Museums, E-Sports, and more.

KD-VW4x4ProK has been specially engineered to cost-effectively create video walls with consumer panels and monitors. The Panel Flip feature rotates the image 180 degrees on the desired outputs, enabling the top row of monitors to be installed upside down, conjoining the narrow frame sides of the displays. Bezel Compensation allows the image to be extended off the screen to create fluid screen transition and five supported video wall layouts (2x2, 4x1, 3x1, 2 mirrored sets of 2x1, and 1x4) make KD-VW4x4ProK the ideal choice to build video walls in any application and price point.

Mirrored HDMI and CAT6 AV outputs enable up to eight connected displays via the four included Rx units- Ideal for dual video walls showing the same thing at the same time.

Alternatively, KD-VW4x4ProK may be used as a 4x4 video matrix so users may view their four connected video sources on their four/eight connected displays. Source selection in video wall or matrix modes is completely seamless and 4K down-conversion features enable integration with legacy 720p and 1080p displays for further savings by the end-user.

4K / UHD content up to 3840 x 2160p 4:2:0 at 60fps is supported, as well as independent audio routing with de-embedding on analog balanced/un-balanced and digital optical connections and surround formats up to 5.1 Dolby® / DTS™. Audio from any source may be selected while in video wall mode.

KD-VW4x4ProK joins a suite of Key Digital IP enabled products that are Web UI and iOS app ready. The engineers at Key Digital have created an easy way for installers and users to switch inputs and control Key Digital systems as if you were standing in front of the unit - all from the PC or portable device. IR from a control system may be input at KD-MLV4x4Pro and extended to control the displays connected to the KD-EXMLVRx units.

Key Features

- **Video Wall Processing:** Transform consumer and professional displays into a video wall with five video wall modes: 2x2, 4x1, 3x1, 2 sets of 2x1, 1x4
- **Seamless Switching:** Un-interrupted screen transitions during source selection
- **Built-In UHDoTP Tx with PoC:** 4 included KD-EXMLVRx units are powered by KD-VW4x4ProK
- **Dual Video Wall / Mirrored Outputs:** Simultaneously active HDMI + UHDoTP mirrored connections per output show same AV signal at same time for a total of 8 possible displays connected
- **Independent Audio Matrix:** Audio output ports may be routed separately from HDMI & UHDoTP ports. Audio from any source may be selected while in video wall mode.
- **Panel Flip:** Enables use of consumer displays by mounting top row upside down and conjoining narrow frame side.

- **Bezel Compensation:** Create a fluid screen transition by removing pixels from top, bottom, left, and right border independently
- **Video Resolution:** Up to 3840 x 2160p 4:2:0 at 60fps supported on inputs & 3840 x 2160p 4:4:4 at 30fps supported on outputs
- **Signal Extension over CAT:**
 - 4K/UHD: Up to 35m (115ft) using CAT5e/6, up to 40m (131ft) using CAT6A STP
 - 1080p: Up to 50m (164ft) using CAT5e/6, up to 60m (197ft) using CAT6A STP
 - Minimum: 5m (17ft) CAT5e/6 cable length required for all resolutions
- **Text Overlay:** Assigned name of each output may be displayed in each window. 16 Characters maximum with variable sizing and location settings.
- **4K Down-Convert:** Integrate 4K sources with legacy 1080p & 720p displays
- **HDCP 2.2 Licensing:** Fully licensed and compatible with HDCP 2.2
- **Built-In Test Patterns:** 9 selectable test screens help expedite installation
- **IR Two-Way:** Extend IR via Rx units to control displays or collect IR from remote to control a source at head-end
- **Web UI:** Control AV routing and other basic functions from any web browser
- **Audio De-Embed:** 6 pin balanced / un-balanced and digital optical outputs
- **Dolby Digital® & DTS™ Audio:** Supports 2-channel and multi-channel surround formats up to 5.1 Dolby® / DTS™
- **Full Buffer System™:** Manages TMDS re-clocking / signal re-generation, HDCP authentication to source & display, and EDID handshake to source
- **EDID Management:** Internal library with 8 EDID AV handshakes per input, in addition to ability to copy from any connected display / output
- **TMDS Re-clocking:** Supports long HDMI connectivity using Key Digital® HDMI cables
- **Deep Color Support:** Up to 8 bits/color
- **Control:** Front panel buttons, IR, RS-232, TCP-IP and Web Control
- **Key Digital® App Ready:** Can be controlled over TCP/IP via Key Digital® App
- **Control System Support:** Key Digital® app ready. Key Digital Management Software™ Pro (KDMS™ Pro) ready, Compass Control® Pro ready. Fully controllable by all IR, RS-232, and TCP/IP supported control systems via open API.

Accessories

- **(1) Power supply**, 12V 5A screw-type, model KDPS60W12VC
- **(1) IR Remote Control**, model KDRMVW44K
- **(4) UHD@TP Rx units**, model KD-EXMLVRx
- **(4) IR Emitters** with 3.5mm mono end. 6ft.
- **(4) IR Sensors** with 3.5mm 4 conductor end. 6ft.
- **(4) 6-pin Phoenix connector** for audio, blue
- **(1) 6-pin Phoenix connector** for unit control
- **(1) USB data cable**, Micro to A, 6ft, USB 2.0
- **(2) Rack ears**

Quick Setup Guide

Begin with the KD-VW4x4ProK and KD-EXMLVRx units, all source, display devices, audio system, and any other connected peripherals powered off.

Connect

1. **Connect video sources** into the HDMI input ports
2. **Connect video displays** to the HDMI output ports on the main and/or Rx units
3. **Connect CAT6 cabling** from the main unit's UHDoTP outputs to the RX unit's UHDoTP input
4. **Connect audio** using the digital or analog outputs ports located on the main unit.
5. **Connect Control System.** For KD-App control and/or IP control from a control system or PC, connect TCP/IP port to network. RS-232 and IR control may also be utilized
6. **(Optional) Connect IR to / from Rx units**
 - a. **If controlling displays:** Connect from control system into IR In/Out ports of main unit and connect IR emitter to the IR Out port of the respective Rx unit (1→1 ... 4→4).
 - b. **If controlling video source:** Connect IR sensor to Rx unit to collect line-of-site IR from a remote. Connect IR emitter to the respective IR In/Out port of main unit (1→1 ... 4→4).
7. **Connect power.** Screw-in power supply to the KD-VW4x4ProK unit, and then connect power to outlets.
8. **Power on** sources, displays, and audio systems to begin use.

Configure

Configure KD-VW4x4ProK with Key Digital Management Software Pro (KDMS Pro). Download [HERE](#)

1. Connect to KD-VW4x4ProK from your PC using the USB micro port on the face of the unit
2. Open the KDMS Pro software and perform a USB scan (2a). Choose "NO" and Start Scan when the USB Device Scan prompt appears (2b)
3. Choose the detected device from the Devices window (fig. 3)
4. Enter the desired unit name (4a), IP address (4b) and IP gateway (4c) settings for the unit
5. Save (5)
6. Select the desired EDID handshake for each video source (6)
7. Enter the desired Input and Output names and press Update Names
8. (Optional) Use the Output Settings section to set the video output format for 4K to 1080p down-convert, establish IR signal flow (default is IR In on the KD-VW4x4Pro4K and IR out on the Rx units to control), and to choose a test pattern for outputting on your display if desired.
9. (Optional) Use the VW Settings section to enable Panel Flip 180 degree image rotation per output and apply bezel compensation settings.

10. Your unit is now ready to control from the web UI, KDMS Pro control panel, KD-App, or by professional control system. Full access to all settings/commands is achieved via terminal session using Tera Term or PuTTY software.

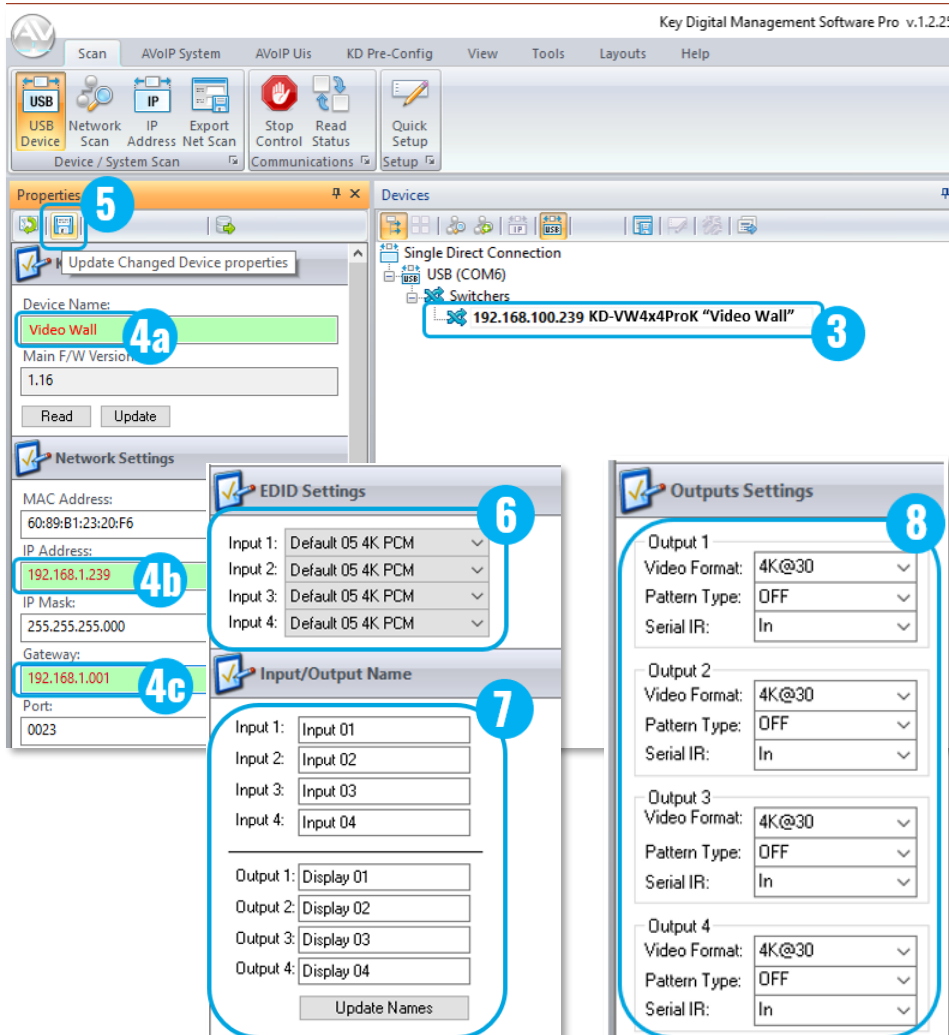
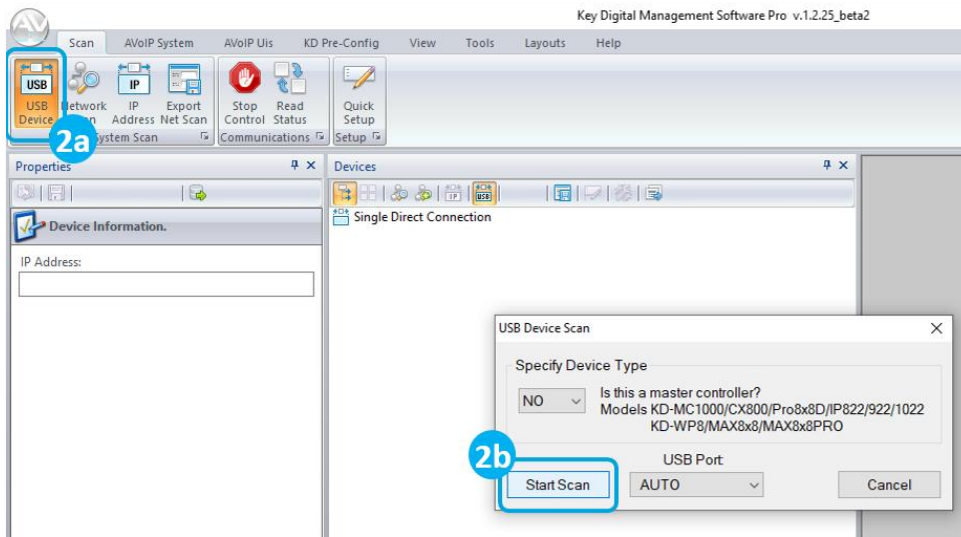

Control

Option 1: Control via Remote Control

Refer to IR Remote Control section for complete control options via IR

- **To enable video wall in desired mode** (see below guide)
 1. VW Mode button (section E)
 2. VW Layout button 1-5 (section D)
 - Note: Source 1 is the default video wall source
- **To select video wall source:**
 1. VW button (section A)
 2. Input button (section C)
- **To set Matrix mode:**
 1. Matrix button (section E)
 - Note: Source 1 is the default source for all outputs
- **To matrix HDMI AV + External Audio:**
 1. A/V button (section A)
 2. Output button (section B)
 3. Input button (section C)

Note: When selecting a new source for while Video Wall mode, only audio de-embed port #1 routes to the video wall source to provide an audio zone synched with the video wall while enabling the other three audio zones to be used for other purposes.

- **To matrix HDMI AV only:**
 1. HDMI button (section A)
 2. Output button (section B)
 3. Input button (section C)
- **External Audio Source Selection:**
 1. Audio button (section A)
 2. Output button (section B)
 3. Input button (section C)
 - Note: this may be used while in Video Wall or Matrix modes

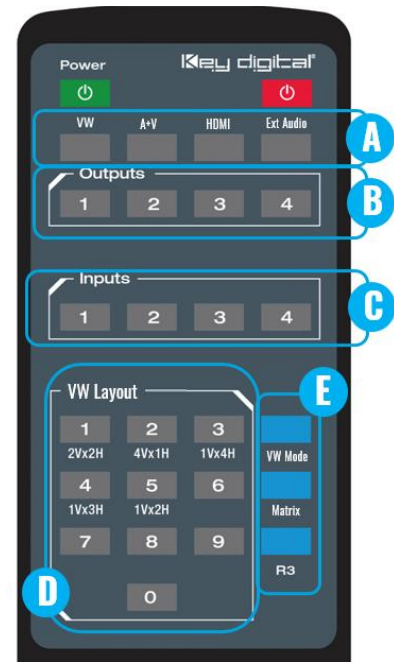

Video Wall Modes

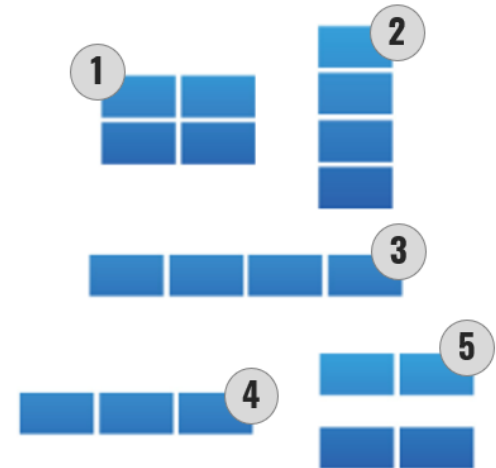

Option 2: Control via KD-App, KDMS Pro™

KD-VW4x4ProK is controllable by Key Digital’s user-friendly [iOS App](#) (downloadable in the App Store) or Key Digital® Management Software™ Pro ([downloadable here](#)) for PC.



1. Connect and configure your KD-VW4x4ProK as described in the Connect & Configure sections
2. Download and open KD-App and/or KDMS™
3. Ensure the iOS device and/or PC computer are on the same network with KD-VW4x4ProK
4. Perform a network scan in the KD-App/KDMS™
5. Select and control the selected KD-VW4x4ProK
6. To enter KDMS Pro end-user mode, key CTRL + ALT + N after selecting the unit in the devices tree.

Note: When selecting a video wall source while in the Video & Audio tab, the audio from the video wall source is routed on external audio output 1

Control UI layouts. The assigned device, source, and display names show for a user-friendly layout.

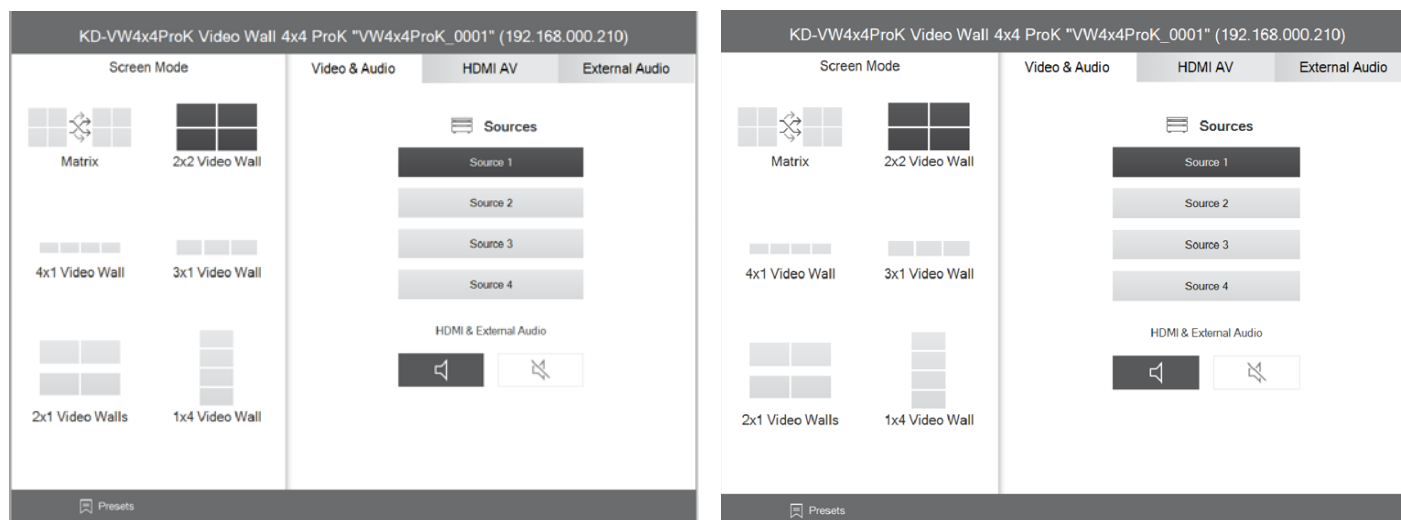

Option 3: Control via web UI

Access KD-VW4x4ProK’s web UI from any phone, tablet, or PC. The web UI shows the input, output, and unit name, for a user-friendly experience.

1. Connect and configure your KD-VW4x4ProK as described in the Connect & Configure sections
2. Ensure the PC, phone, or tablet are on the network with KD-VW4x4ProK
3. Enter IP Address of KD-VW4x4ProK unit into the web browser search bar
4. Enter the password. Default password is “admin”
5. Use the web UI to choose video wall layout (5a) and video wall source selection (5b) or select the source for each HDMI (5c) and/or external audio output independently (5d).

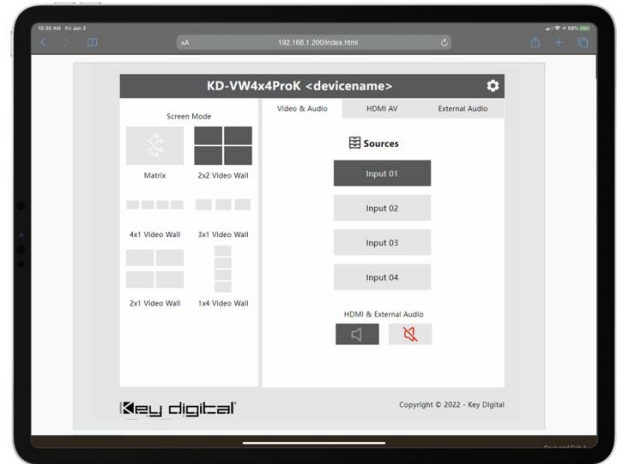

Note: When selecting a video wall source while in the Video & Audio tab, the audio from the video wall source is routed on external audio output 1



Option 4: Control via professional control system

KD-VW4x4ProK allows control over serial interface for bi-directional communication.

- **For RS-232 control** use pins 4, 5, and 6 of the Unit Control port. Baud Rate is 57,600
- **For TCP/IP control** the default static IP address is 192.168.1.239, with port 23.

Default static IP address:
192.168.1.239, port 23

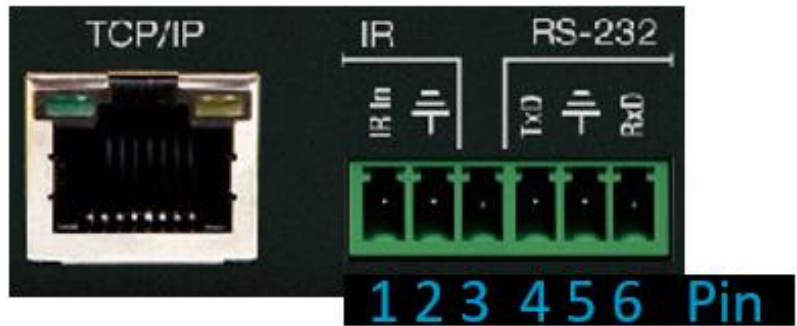

- KD-VW4x4ProK supports KD’s standard matrixing protocol, so if you have controlled a KD matrix with a third-party control system before, you will likely have success with the same driver/module.

a. Video Wall / Matrix Switching HDMI AV + External Audio together

- i. SPOxxSlyy xx = output (01 if in video wall mode, or 01-04 in matrix mode),
yy = input (01-04)

Note: When selecting a new source for while Video Wall mode, only audio de-embed port #1 routes to the video wall source to provide an audio zone synced with the video wall while enabling the other three audio zones to be used for other purposes.

b. Video Wall / Matrix Switching HDMI AV Only

- i. SPOxxSByy xx = output (01 if in video wall mode, 01-04 in matrix mode)
yy = input (01-04)

c. Matrix Switching External Audio only

- i. SPOxxSAyy xx = output (01-04), yy = input (01-04)

Note: this may be used while in Video Wall or Matrix mode

d. Video Wall / Matrix mode select

- i. SPOOMx x = 0 (matrix), 1 (2x2 VW), 2 (1Hx4V VW), 3 (4Hx1V VW),
4 (3Hx1V), 5 (2 mirrored sets of 2Hx1V VWs)

- **A carriage return is required at the end of each string.** See the TCP/IP and RS-232 Commands section for full command set and protocol.



Test for proper operation of the unit and cables in your system before permanently securing the unit for final installation. Ensure that you leave enough ventilation space to provide sufficient airflow and cooling

Application Example

Dual mirrored video walls achieved by using HDMI + UHDoTP AV. Audio de-embed ports connect to amplifiers for up to 4 possible unique audio zones. Control over IP from Web UI on any phone, tablet, or PC.

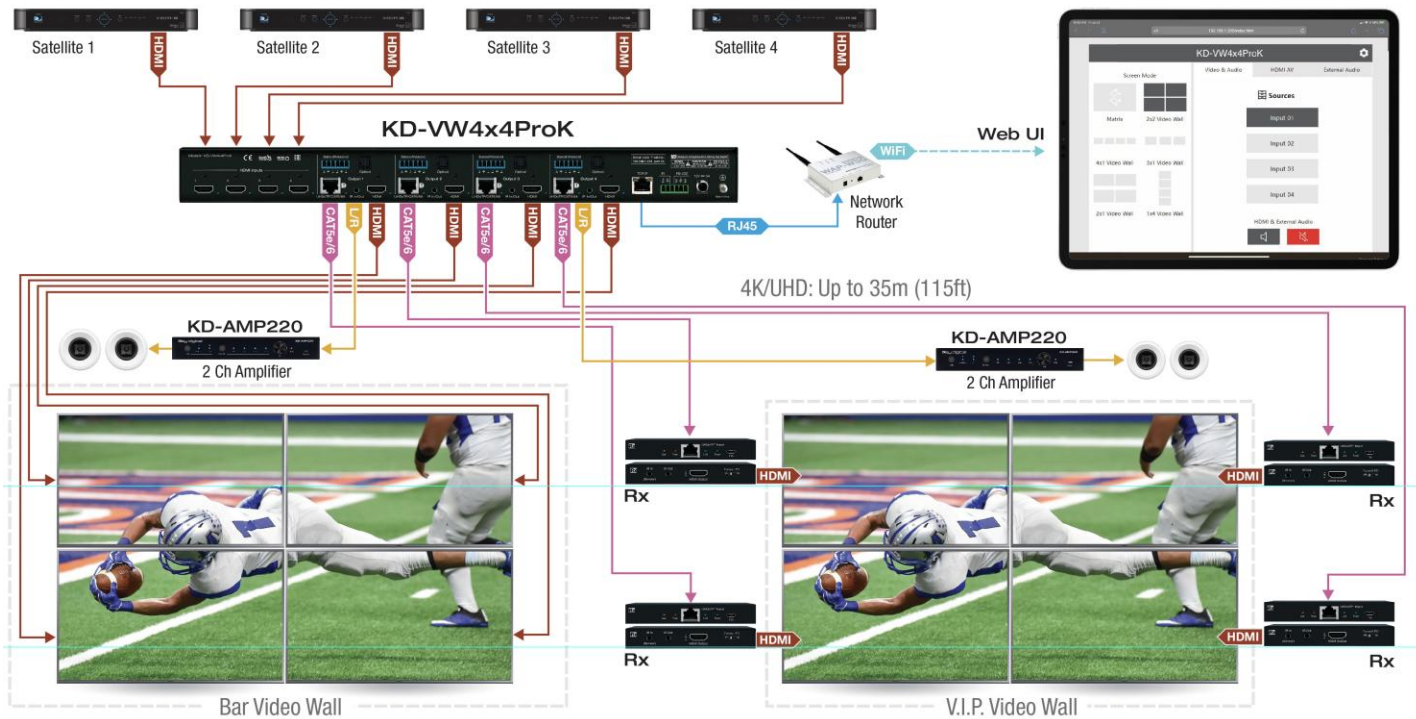

KD-VW4x4ProK Connections, and LEDs

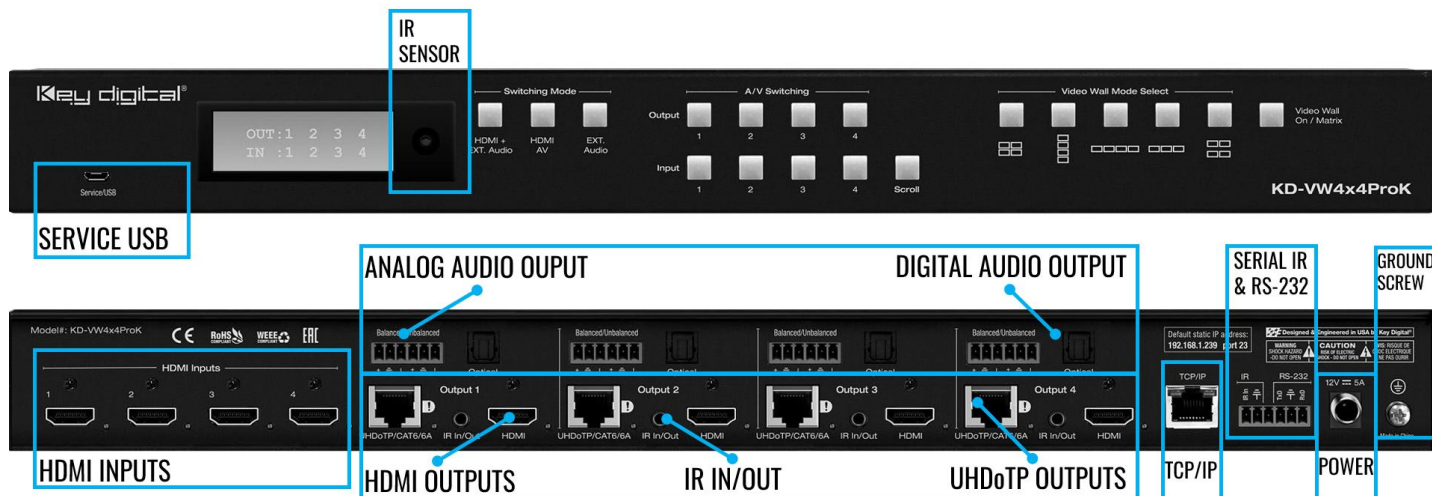

HDMI Inputs (4): Using an HDMI cable, connect your HDMI sources.

- Supports up to UHD/4K @ 60fps [4:2:0], 8 bit color, 10.2Gbps maximum bandwidth
- Compliant with HDMI 2.0, HDCP 2.x and previous
- Supports surround audio formats including Dolby®, DTS™ (formats up to 5.1 / 6.1)
- Does not support HDR, CEC, ARC, or 3D
- For Display Port sources use active DP to HDMI converter
- **Blue** Link LED to the right of port illuminates with an active HDMI signal from source.
- **Note:** If a selected source has no incoming signal, a floating “NO SIGNAL” displays on screen.

HDMI Outputs (4): Using an HDMI cable, connect your HDMI displays.

- Supports up to UHD/4K @ 30fps [4:4:4], 8 bit color, 10.2Gbps maximum bandwidth
- Compliant with HDMI 2.0, HDCP 2.x and previous
- Supports surround audio formats including Dolby®, DTS™ (formats up to 5.1 / 6.1)
- Does not support HDR, CEC, ARC, or 3D
- Output resolution of 4K @ 30fps, 1080p @ 60fps, or 720p @ 60fps may be selected per output using KDMS Pro software or by sending command via TCP/IP or RS-232
- For Display Port monitors use active HDMI to DP converter
- **Blue** Link LED to the right of port illuminates with active Hot Plug Detection voltage from the display.

UHDoTP Output (4): Connect a CAT5e/6 cable to the Rx unit's UHDoTP Input port using CAT5e/6 cabling in 568-B termination.

- Supports up to UHD/4K @ 30fps [4:4:4], 8 bit color, 10.2Gbps maximum bandwidth
- Compliant with HDMI 2.0, HDCP 2.x and previous.
- Distance performance:
 - UHD/4K: Up to 115ft (35m) using CAT5e/6, up to 40m (131ft) using CAT6A STP
 - 1080p: UP to 164 ft (50m) using CAT5e/6, up to 60m (197ft) using CAT6A STP
- Supports Dolby®, DTS™ (5.1 / 6.1 formats max)
- Does not support HDR, CEC, ARC, or 3D
- Output resolution of 4K @ 30fps, 1080p @ 60 fps, or 720p @ 60fps may be selected per output using KDMS Pro software or by sending command via TCP/IP or RS-232
- Provides 12V Power over CAT to each KD-EXMLVRx
- **Blue** Link LED to the right of port illuminates with active link with KD-EXMLVRx unit
- **Important Notes:**
 - Minimum CAT5e/6 cable length required: 17ft (5m)
 - Not compatible with HDBaseT or third-party Rx. Connecting to incompatible Rx may cause damage and result in void of warranty.

Analog Audio Outputs (4): 6-pin phoenix balance / un-balanced

- Provides 2ch balanced or un-balanced analog audio output from the selected HDMI input source.
- The Pin assignment for the audio is as follows:

- Left + is Pin 1; Left - is Pin 3; Left Ground is Pin 2.
- Right + is Pin 4; Right - is Pin 6; Right Ground is Pin 5.
- For un-balanced audio, use the + and Ground pins of each channel
- Drives audio signals up to 2VRMS with a sampling rate of 192KHz
- There are no volume, tone, or latency control features
- There are no format conversion features. For example, to achieve 2ch analog audio output, the selected HDMI input source audio format must be 2ch.

Digital Audio Outputs (4): Optical

- Provides digital audio output from the selected HDMI input source.
- Supports PCM, SPDIF (IEC 60958), Dolby Digital®, and DTS™ up to 5.1 / 6.1
- There are no volume or tone control features
- There are no format conversion features. For example, to achieve 2ch analog audio output, the selected HDMI input source audio format must be 2ch.

Audio Input Signal Format	Audio L/R Output	Digital Audio Output (Optical)
2ch PCM	Pass-Through	Pass-Through
Multi-Channel PCM	Front L/R Pass-Through	MUTE
Dolby DTS	MUTE	Pass-Through
HD Audio	MUTE	MUTE

Note about audio de-embed outputs: When selecting a new source while Video Wall mode, only audio de-embed port #1 routes to the video wall source so as to provide an audio zone synched with the video wall while enabling the other three audio zones to be used for other purposes.

IR In/Out (4):

- The default setting is IR Input for the 4x IR In/Out connections. Direction may be changed using KDMS Pro software, TCP/IP or RS-232.
- IR In/Out ports correspond to their respective Rx unit. IR is not routable
- The **KD-VW4x4ProK** IR Input supports **Serial IR input only**. IR sensor connection not supported.
 - The **KD-EXMLVRx** IR Inputs support the **IR Sensor only**. Serial / hard-wired IR connection not supported.
- Maximum supported IR burst frequency is 55kHz.
- Only the provided IR Emitters should be used. Third-party emitters may not be compatible.
- Pinout:
 - Tip = IR in/out signal, Sleeve = Ground
- RS-232 extension is not supported

Service USB (1):

- Micro USB port
- Used for configuration and control from PC via KDMS Pro, KDMS, or third-party control terminal
- Used for firmware updates (consult with Key Digital tech support before updating firmware).

- **Note:** After updating firmware, all unit settings are restored to defaults except IP information. Please collect all customized settings info before loading firmware.
- Supports USB driver for Windows, Mac
- Will register as “Prolific USB-to-Serial Comm Port in Device Manager
- Can be used as RS-232 control port. Baud rate is 115,200.

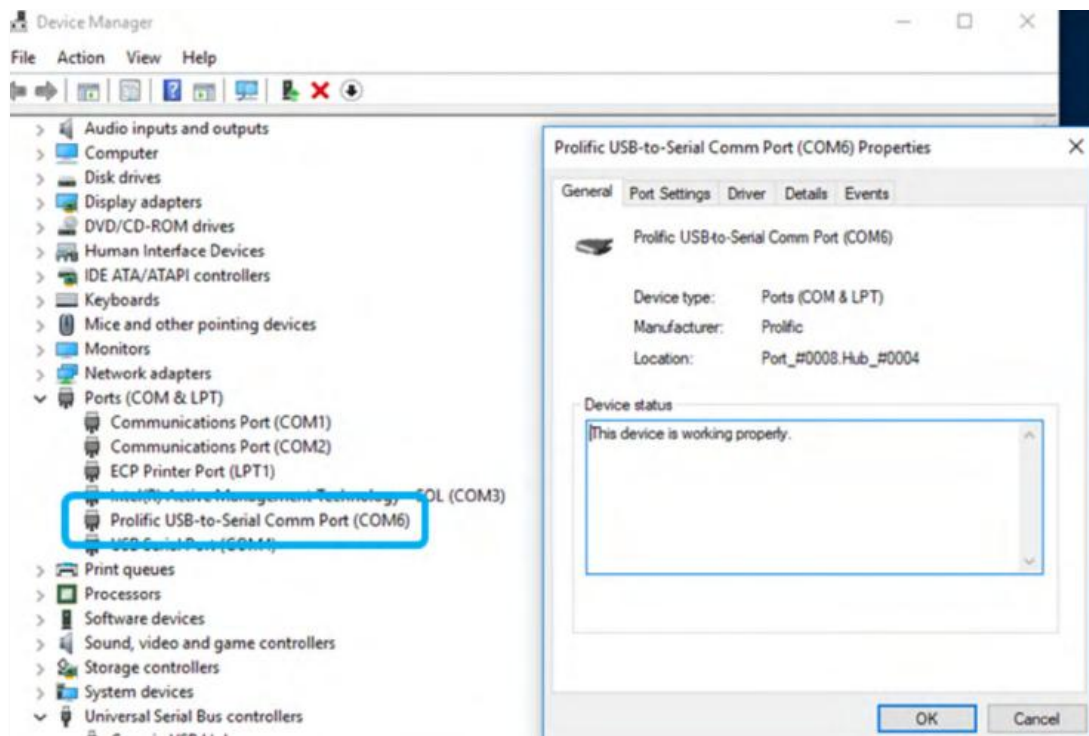

Ground Screw: Connect to ground screw on rack or direct to ground wire from ground post to ensure solid grounding of the main unit.

TCP/IP Unit Control: Used for unit control from a control system and/or PC

- Connect ethernet cable from the KD-VW4x4ProK to a network router or connect a straight through cable directly from a PC
- Default static IP address is 192.168.1.239, port 23
- Unit configuration, control, and firmware updates are achieved with Key Digital Management Software™ Pro (KDMS™ Pro) downloaded [HERE](#).
- See TCP/IP and RS-232 Commands section for full API

Default static IP address:
192.168.1.239, port 23

RS-232 & IR Unit Control: Used for unit control from a control system and/or PC

- 6-Pin Terminal Block for IR and RS-232
- Pin out:
 - Pin 1 = Serial (Wired) IR In
 - Pin 4 = RS-232 Tx Data
 - Pin 2 = IR Ground
 - Pin 5 = RS-232 Ground
 - Pin 3 = No Connection
 - Pin 6 = RS-232Rx Data
- See TCP/IP RS-232 Commands section for full API

IR Sensor: Mount IR an IR emitter from control system or IR connection block over the optical IR Sensor on the face of the unit. Refer to IR Remote Control section for correct button press sequence

KD-EXMLVRx Connections, LEDs, and Slide-Switches

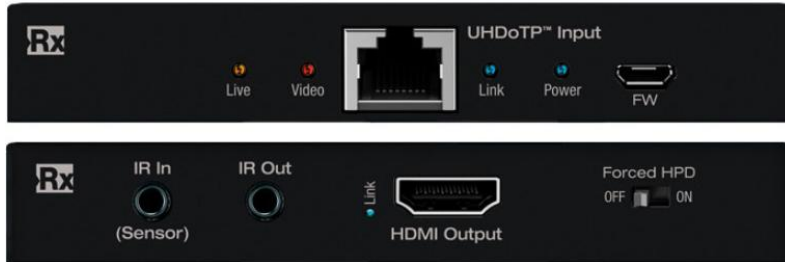

HDMI Output: Using an HDMI cable, connect your HDMI displays.

- Supports up to UHD/4K @ 30fps [4:4:4], 8 bit color, 10.2Gbps maximum bandwidth
- Compliant with HDMI 2.0, HDCP 2.x and previous
- Supports surround audio formats including Dolby®, DTS™ (formats up to 5.1 / 6.1)
- Does not support HDR, CEC, ARC, or 3D
- Output resolution of 4K @ 30fps, 1080p @ 60fps, or 720p @ 60fps may be selected per output using KDMS Pro software or by sending command via TCP/IP or RS-232
- Source selection and down-convert settings are mirrored on UHDoTP and HDMI output connections of the same port number.
- For Display Port monitors use active HDMI to DP converter

UHDoTP Input: Connect a CAT5e/6 cable to the Main unit's UHDoTP Output port using 568-B termination.

- Supports up to UHD/4K @ 30fps [4:4:4], 8 bit color, 10.2Gbps maximum bandwidth
- Compliant with HDMI 2.0, HDCP 2.x and previous
- Distance performance:
 - UHD/4K: Up to 115ft (35m) using CAT5e/6, up to 40m (131ft) using CAT6A STP
 - 1080p: UP to 164 ft (50m) using CAT5e/6, up to 60m (197ft) using CAT6A STP
- Supports Dolby®, DTS™ (5.1 / 6.1 formats max)
- Does not support HDR, CEC, ARC, or 3D
- Output resolution of 4K @ 30fps, 1080p @ 60 fps, or 720p @ 60fps may be selected per output using KDMS Pro software or by sending command via TCP/IP or RS-232
- Provides 12V Power over CAT to KD-EXMLVRx
- **Important Notes:**
 - Minimum CAT5e/6 cable length required: 17ft (5m)
 - Not compatible with HDBaseT or third-party Rx. Connecting to incompatible Rx may cause damage and result in void of warranty.

IR Out:

- Connect the included IR emitter to control your display / projector.

- Pinout: Tip = IR in/out signal, Sleeve = Ground
- If the respective IR In/Out port on KD-VW4x4ProK has been set to IR Output, this port is no longer active

IR In:

- Connect the included IR sensor to collect line-of-sight IR from your device's remotes
- Pinout: Tip = IR in/out signal, Ring = +5V sensor power, Sleeve = Ground
- By default, this port is not active. You must set the respective IR In/Out port on KD-VW4x4ProK to IR Output for this port to work.
- The **KD-EXMLVRx** IR Input port supports the **IR Sensor only**. Serial / hard-wired IR input not supported.
- Only the provided IR Sensor should be used. Third-party sensors may not be compatible and/or may result in damage
- The included IR Sensor Receives signals from a 90° angle at up to 30 ft. away.
- Maximum supported IR burst frequency is 55kHz.
- RS-232 extension is not supported on this port.

LEDs

Power (Blue)

- Solid illumination during power on state, as provided by healthy connection with power supply and healthy PoC extension.
- Steady blink if unit has a power short

Link (Blue)

- Solid illumination from healthy UHDoTP link between Tx and Rx units

Video (Red)

- Illumination with active TMDS (video + audio) signal
- Off with no TMDS (video + audio) signal

Live (Amber)

- Steady blink from healthy unit CPU state

HDMI Link (Blue)

- Solid illumination from active Hot Plug Detection voltage with connected display/output device

Forced HPD Slide Switch: In cases of many layers of connectivity or non-standard devices in-line, hot plug detection (HPD) may be lost or drop below standard levels, leading to the video display not detecting a connected source and resulting in no image.

- If set to ON, Hot Plug Detection (HPD) voltage is forced at the HDMI connection of the Rx unit. The connected display will be fed a constant voltage to inform the device that a partner is always connected and active.
- If set to OFF, Hot Plug Detection (HPD) voltage is passed thru from connected source to the display

FW (firmware) USB:

- Micro USB port
- Used for firmware updates (consult with Key Digital tech support before updating firmware)

- **Note:** After updating firmware, all unit settings are restored to defaults except IP information. Please collect all customized settings info before loading firmware.

Front Panel Control & LCD

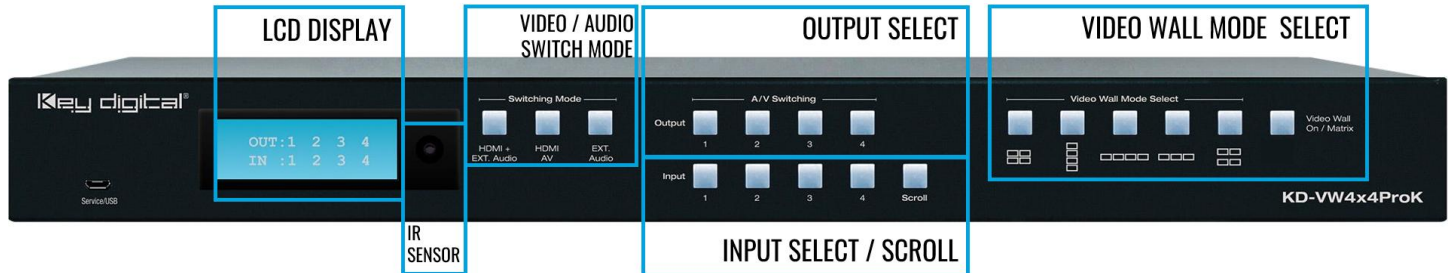

- **To enable video wall in desired mode:**
 1. Video Wall On / Matrix button (button illuminates indicating VW Mode)
 2. Video Wall Mode selection button

Notes: Source 1 is the default video wall source. If the Video Wall On / Matrix button is already illuminated, you may skip step 1 to choose another video wall mode.
- **To select video wall source:**
 1. Video Wall On / Matrix button (button illuminates indicating VW Mode)
 - 2a. Input select button to choose discrete input.
 - 2b. Input Scroll button to advance to next input

Notes: With HDMI AV switching mode button illuminated, only the HDMI ports route to the selected video wall input. With Ext. Audio button illuminated, only external audio output 1 routes to the selected video wall input.

Input scroll button only works while in Video Wall mode.

If the Video Wall On / Matrix button is already illuminated, you may skip step 1.
- **Matrix Routing HDMI AV only:**
 1. HDMI AV button (button illuminates to indicate selection)
 2. Output button
 3. Input button
- **Matrix Routing External Audio only:**
 1. Ext. Audio button (button illuminates to indicate selection)
 2. Output button
 3. Input button

Factory Default Reset via Front Buttons: Simultaneously press & hold the HDMI AV + Video Wall On / Matrix buttons for 10 seconds to reset KD-VW4x4ProK to its factory settings:

- All outputs select source 1
- EDID setting 5 is applied at all HDMI inputs
- IP Address, input & output naming, and all other applied settings are defaulted

LCD Display

- A. During bootup, the model number and unit's IP address are shown
- B. During Video Wall selection, the selected source number and VW layout is shown
- C. During Matrixing for HDMI and/or External Audio, the selected source number is shown for each output

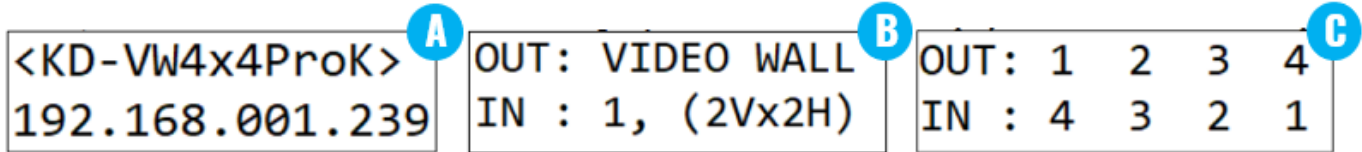

IR Remote Control

- **To enable video wall in desired mode** (see below guide)
 1. VW Mode button (section E)
 2. VW Layout button 1-5 (section D)
 - Note: Source 1 is the default video wall source
- **To select video wall source:**
 1. VW button (section A)
 2. Input button (section C)

Note: When selecting a video wall source, the audio from the video wall source is routed on external audio output 1
- **To set Matrix mode:**
 1. Matrix button (section E)
 - Note: Source 1 is the default source for all outputs
- **To matrix HDMI AV + External Audio:**
 1. A/V button (section A)
 2. Output button (section B)
 3. Input button (section C)
- **To matrix HDMI AV only:**
 1. HDMI button (section A)
 2. Output button (section B)
 3. Input button (section C)
- **External Audio Source Selection:**
 1. Audio button (section A)
 2. Output button (section B)
 3. Input button (section C)
 - Note: this may be used while in Video Wall or Matrix modes
- **To enable / disable Panel Flip (180deg image rotation) on output:**
 1. R3 button (section E)
 2. Output # (section B)

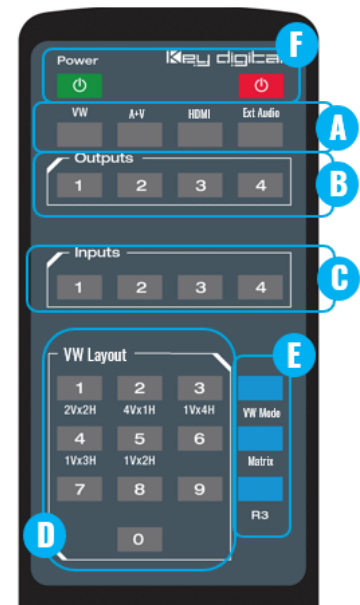

Video Wall Modes

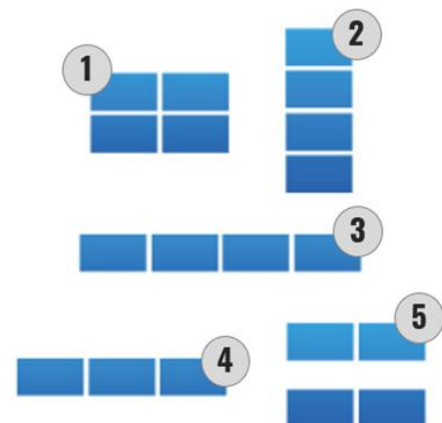

3. VW Layout button 1 (enable) or 0 (disable)

- **To enable / disable Debug Mode on output:**
 1. R3 button (section E)
 2. HDMI button (section A)
 3. Output # (section B)
 4. VW Layout button 1 (enable) or 0 (disable)

- **To set EDID handshake for Source from built-in EDID library:**

1. R3 button (section E)
2. Input # (section C)
3. VW Layout # (section D) according to EDID handshake table

Note: A unique EDID handshake may be chosen for each HDMI input

EDID #	EDID Handshake Description
1	1080i 60fps with 2ch PCM audio
2	1080i 60fps with PCM, DTS/Dolby surround
3	1080p 60fps with 2ch PCM audio
4	1080p 60fps with PCM, DTS/Dolby surround
5	4Kx2K 60fps with 2ch PCM audio
6	4Kx2K 60fps with PCM, DTS/Dolby surround
7	DVI 1280x720 60fps, no audio
8	DVI 1920x1080 60fps, no audio

Web UI

Use the web UI to select the desired video wall mode and control AV routing as well as applying commonly needed settings for ease of installation and use. The web UI displays the input, output and devices names applied for a user-friendly experience.

1. Open web browser and enter KD-VW4x4ProK’s IP address. The Default IP address is 192.168.1.239
2. Enter password. The default password is **admin** and may be adjusted in the network settings.
3. Use the **Screen Mode** selection at the left-side of screen to choose desired video wall layout or enter matrix mode.
4. Use the **Video & Audio tab** to simultaneously route the desired Source to the HDMI Audio + Video as well as the External Audio Ports to that selected source.

Note: When selecting a new source for while Video Wall mode, only audio de-embed port #1 routes to the video wall source to provide an audio zone synched with the video wall while enabling the other three audio zones to be used for other purposes.
5. Use the **HDMI AV tab** to route the desired Source to route to the HDMI output only.
6. Use the **External Audio** tab to independently route the desired audio source on the selected output / audio zone.
7. Press the **Settings Button** in the upper-right corner of the web UI to access most common installer setup options. These settings may also be applied using KDMS Pro or via IP/RS232 command strings:
 - a. Enter the **Naming Settings** tab (7a) to assign a user-friendly Device Name, Input Name, and Output Name settings.
 - b. Enter the **Video Settings** tab (7b) to apply Panel Flip and bezel adjustment settings. See the [Panel Flip](#) and [Bezel Adjustment](#) sections for more information.
 - c. Enter the **Network Settings** tab (7c) to update the IP settings and web UI access password.

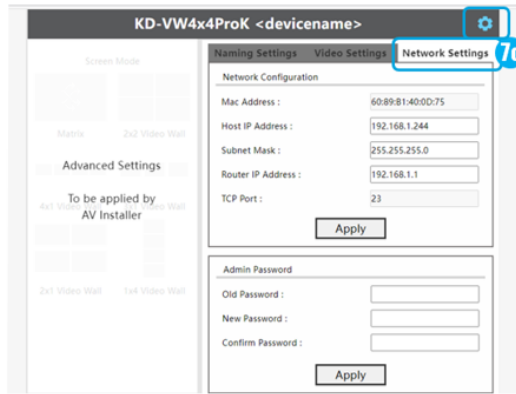
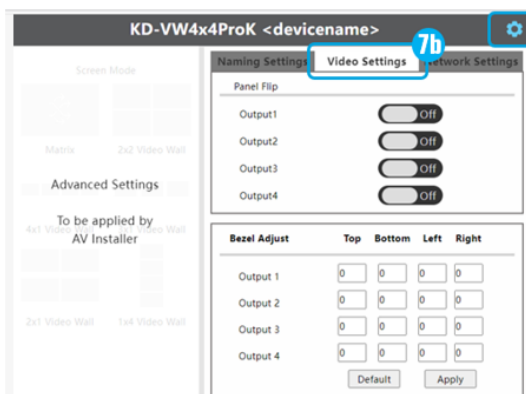
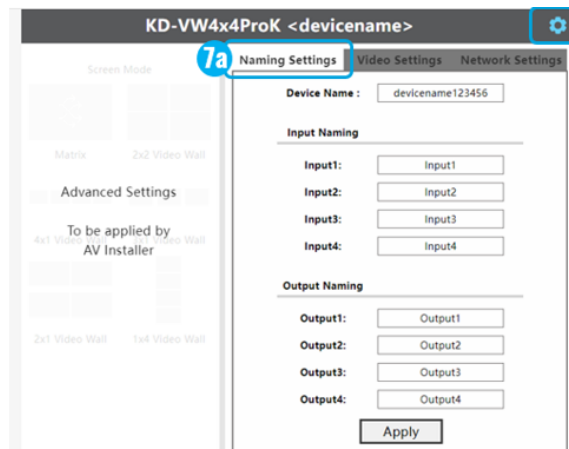
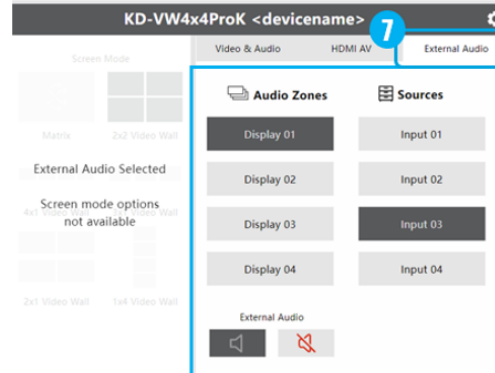
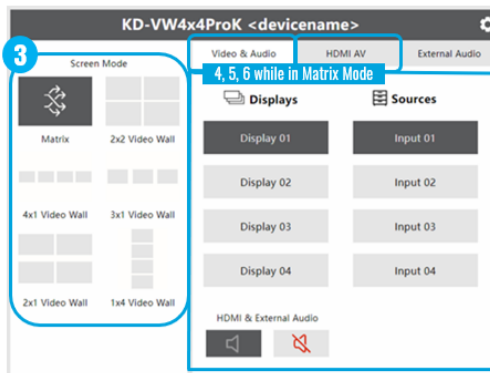
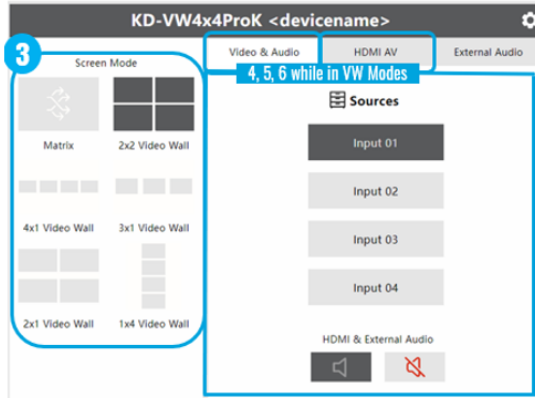

Video Wall Modes

KD-VW4x4ProK supports five video wall modes

Important note about video wall source content:

It is necessary to obtain/create content designed for display in the aspect ratio of the video wall mode but is output by your HDMI source device in 16:9





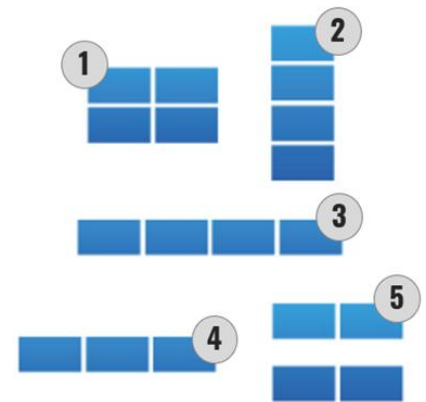

- A common display’s aspect ratio is 16:9.
- Example: Working in the 1H x 4V mode, the width is 1 to 1 (1:1), but the height is 1 to 4 (1:4) because of the 4 vertical displays.
- Therefore, the correct source content should be 16:36
- Tip: 16 times 1 equals 16 for the width. 4 times 9 equals 36 for the height.



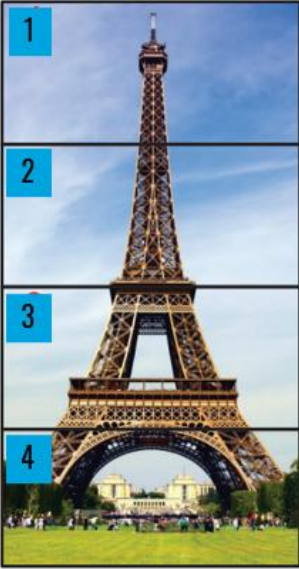

Video Wall Modes



#	Video Wall Mode 1	Layout
1	2 Horizontal x 2 Vertical Ideal aspect ratio of source content: 16:9	

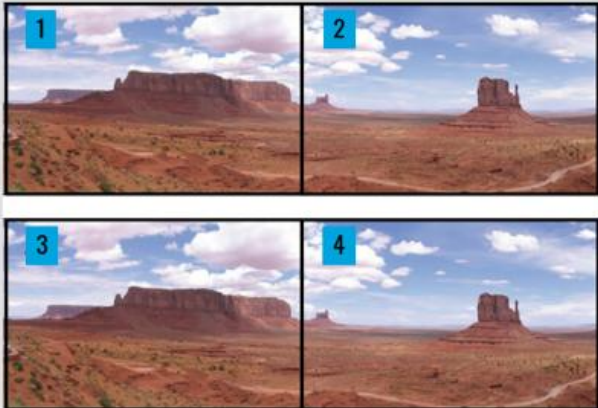

#	Video Wall Mode 2	Layout
2	1 Horizontal x 4 Vertical Ideal aspect ratio of source content: 16:36	
	Original content as viewed on a 16:9 display 	
	1H x 4V VW mode selected on KD-VW4x4ProK 	
#	Video Wall Mode 3	Layout
3	4 Horizontal x 1 Vertical Ideal aspect ratio of source content: 64:9	
	Original content as viewed on a 16:9 display 	
	4H x 1V VW mode selected on KD-VW4x4ProK 	

#	Video Wall Mode 4	Layout
4	3 Horizontal x 1 Vertical Ideal aspect ratio of source content: 48:9	
	Original content as viewed on a 16:9 display 	
	3H x 1V VW mode selected on KD-VW4x4ProK 	
#	Video Wall Mode 5	Layout
5	2 Mirrored sets of 2 Horizontal x 1 Vertical Ideal aspect ratio of source content: 32:9	
	Original content as viewed on a 16:9 display 	
	2H x 1V VW mode selected on KD-VW4x4ProK 	

Panel Flip

Enables use of consumer monitors by mounting top row displays upside down and conjoining narrow frame sides.

- May be enabled via IR, KDMS Pro, TCP/IP and or RS-232 commands
- IR Remote button sequence is:
 - R3 button (section E)
 - Output # (section B)
 - VW Layout button 1 (enable) or 0 (disable)
- TCP/IP or RS-232 command is:
 - SPOxxDUy
 - Where xx = Output # 01-4
 - Where y = E (enable) or D (disable)

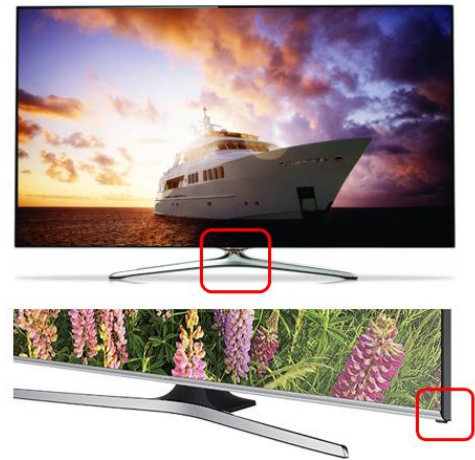
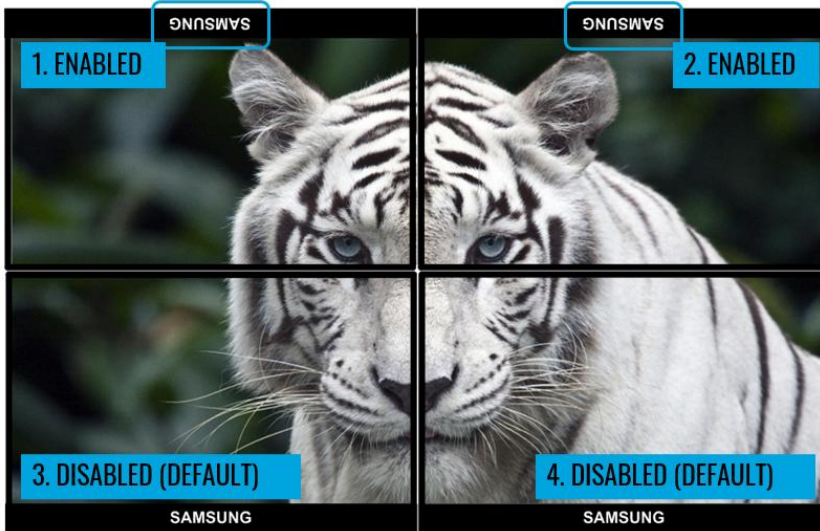

Bezel Control

While in video wall mode, the video signal to each display may be extended up to 99 pixels beyond the top, bottom, left, or right edge of the monitor’s screen. This setting is recommended for video entertainment applications (ie sports bar), but not for data viewing applications like spreadsheets because some content may be extended off screen.

This setting is applied using the following TCP/IP or RS-232 commands:

- Top border: SPOxxVCTyy
- Bottom border: SPOxxVCByy
- Left border: SPOxxVCLyy
- Right border: SPOxxVCRyy

Where xx = Output # (01-04)

Where yy = Number of pixels (00-99)

Example: 2x2 Video Wall

- Display 1 (top-left) needs no bezel control adjustments
- Display 2 (top-right) image gets extended to the left
- Display 3 (bottom-left) image gets extended up
- Display 4 (bottom-right) image gets extended to the left and up

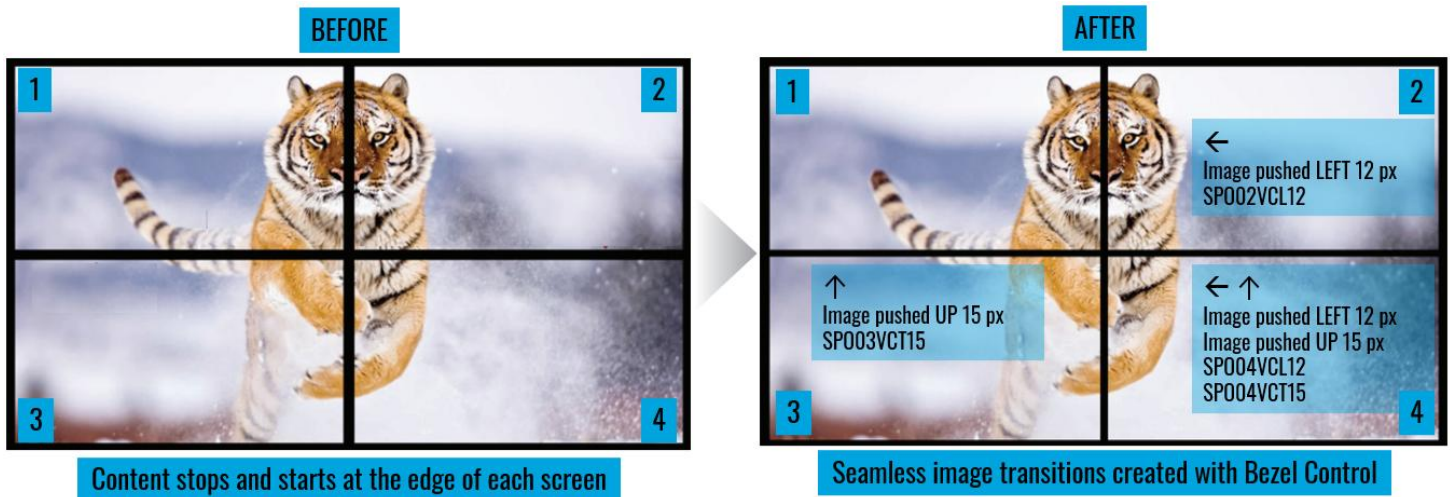

Text Overlay

Text overlay available while in video wall mode.

- The assigned name of each display may be displayed in each window.
- This can be helpful if confused about the proper location of each display within the video wall.
- By default, the text shows as “Display 01” ... “Display 04”.
- Use KDMS Pro or send commands via IP/RS-232 to set the name of each source, X/Y location of each text box, and to enable/disable the text overlay setting
- 16 characters maximum with variable sizing (large / medium / small).
- The below image is an example of “large” text overlay applied.



- The X/Y grid for text box location varies based on output resolution setting of the KD-VW4x4ProK unit:
 - 4K: X = 0-3839, Y = 0-2059
 - 1080p: 0-1919, Y = 0-1079
 - 720p: X = 0-1279, Y=0-719
- The default X/Y value for the text box location is X = 100, Y = 100 (regardless of 4K, 1080p, or 720p output resolution)

TCP/IP and RS-232 Commands

TCP/IP Connection Protocol

- Default IP address = 192.168.1.239
- TCP/IP Port Number = 23
- **Notes:** Use Raw / Other service, not Telnet
Maximum of one TCP/IP socket supported at a time.
Simultaneous TCP/IP and web sockets are supported. Multiple web sockets are supported.

Default static IP address:
192.168.1.239, port 23

RS-232 Connection Protocol

- Baud Rate = 57,600 bits per second as default
- Data Bits = 8
- Stop Bits = 1
- Parity = None
- Flow Control = None

Notes:

- Commands are not case-sensitive
- Spaces are shown for clarity; commands should NOT have any spaces
- After a new command is received, a prompt should be sent back
- **Carriage Return is required at end of each string**

Help Command (H). Returns entire API in readable format:

```
-----
--                               Key Digital Systems HELP                               --
-----
-- KD-VW4x4ProK                               F/W Version : 1.18 --
--
-- H      : Help                               --
-- STA    : Show Global System Status         --
-- PF     : Power Off                          --
-- PN     : Power ON                          --
--
-- Video Input Setup Command : ( xx=[01~04,A=A11] ) --
-- SPI xx ON/OFF    : Set Input xx ON/OFF    --
--
```

```

-- Video Output Setup Command : --
-- (xx=[01~04,A=All], yy=[01~04, U=Up, D=Down]) --
-- SPO xx SB yy : Set Video Output xx to Input yy --
-- SPO xx SI yy : Set Video-Audio Output xx to Input yy --
-- SPO xx PG y : Set Video Output xx with Video Pattern y=[0~9] --
-- (0=OFF, 1=Back Screen, 2=Horizontal Gray Bars ) --
-- (3=Horizontal Gray Scale, 4=Vertical Gray Scale, 5=Color Bars ) --
-- (6=Red Screen, 7=Green Screen, 8=Blue Screen, 9=Grid ) --
-- SPO xx VF yy : Set Video Output xx to Video Format yy --
-- [ yy : 01 = 4K@30, 02 = 1080p@60, 03 = 720p@60 ] --
-- SPO xx DBG ON/OFF : Set Video Output xx's Debug Mode to ON/OFF --
-- --
-- OSD Setup Command : xx=[01~04, A=All] --
-- SPO xx OSD ON/OFF : Set Output xx OSD ON/OFF --
-- SPO xx OSP aaaa.bbbb : Show Output xx Name at X/Y-axis(aaaa/bbbb) --
-- aaaa = [0000 ~ 3839], bbbb = [0000 ~ 2159] --
-- SPO xx OSS y : Set Font Size of Output xx OSD by y = [1~3] --
-- y [1=12x24px, 2=24x48px, 3=48x96px] --
-- --
-- Audio Output Setup Command : --
-- (xx=[01~04,A=All], yy=[01~04, U=Up, D=Down]) --
-- SPO xx SA yy : Set Audio Output xx to Input yy --
-- SPO xx HA E/D : Set HDMI/UHDoTP Audio Output xx to Enable/Disable --
-- SPO xx AA E/D : Set Balanced Audio Output xx to Enable/Disable --
-- SPO xx DA E/D : Set Optical Output xx to Enable/Disable --
-- --
-- IR Setup Command : (xx=[01~04,A=All], y=[1~2]) --
-- SPO xx IRS y : Set Output xx IR Direction to y [1=IN, 2=OUT] --
-- --
-- Video Wall Mode Setup Command : ( xx=[01~04], z=[1~9] ) --
-- SPO OM z : Set Output Mode by z --
-- z [0=4x4 Matrix Switch, 1=2Hx2V Video Wall(VW), 2=1Hx4V VW ] --
-- [3=4Hx1V VW, 4=3Hx1V VW, 5=2Hx1V VW, 6=1Hx3V VW, 7=1Hx2V VW ] --
-- SPO xx DU E/D : Set Flip a Video Enable/Disable for Output xx --
-- --

```

```

-- The Bezel Control in Video Wall Mode ( xx=[01~04], yy=[00~99] )      --
-- SPO xx VCL yy : Set yy pixels on the Left Border of Output xx      --
-- SPO xx VCR yy : Set yy pixels on the Right Border of Output xx     --
-- SPO xx VCT yy : Set yy pixels on the Top Border of Output xx       --
-- SPO xx VCB yy : Set yy pixels on the Bottom Border of Output xx    --
--                                                                    --
-- Input/Output/Device Naming Commands (Max. 16 Chars)                --
-- SPI xx WN cccccccccccccccc : Write Input xx Name                  --
-- SPI xx RN                    : Read Input xx Name                 --
-- SPO xx WN cccccccccccccccc : Write Output xx Name                --
-- SPO xx RN                    : Read Output xx Name                --
-- SPC WN cccccccccccccccc    : Write Device Name                   --
-- SPC RN                      : Read Device Name                   --
--                                                                    --
-- Network Setup, ( xxx=[000-255], zzzz=[0001~9999] )                --
-- SPCETIPA xxx.xxx.xxx.xxx : Set Host IP Address to xxx.xxx.xxx.xxx  --
-- SPCETIPM xxx.xxx.xxx.xxx : Set Net Mask to xxx.xxx.xxx.xxx        --
-- SPCETIPR xxx.xxx.xxx.xxx : Set Route IP Address to xxx.xxx.xxx.xxx --
-- SPCETIPP zzzz            : Set TCP/IP Port to zzzz                --
-- SPCETIPB                  : Apply New Network Config              --
--                                                                    --
-- EDID Setup Command ( xx=[01~04,A=All], yy=[01~04], zz=[01-08] )  --
-- SPCEDID xx H yy : Copy EDID from HDMI Ouput yy to Input xx       --
-- SPCEDID xx C yy : Copy EDID from UHDoTP Ouput yy to Input xx     --
-- SPCEDID xx D zz : Copy EDID from Default EDID zz to Input xx     --
--   DEFAULT EDID 01 : HDMI 1080i@60, 2CH PCM Audio                 --
--   DEFAULT EDID 02 : HDMI 1080i@60, Audio PCM,DTS/DOLBY           --
--   DEFAULT EDID 03 : HDMI 1080p@60, Audio 2CH PCM Audio           --
--   DEFAULT EDID 04 : HDMI 1080p@60, Audio PCM,DTS/DOLBY           --
--   DEFAULT EDID 05 : HDMI 4Kx2K@60/10G, 2CH PCM Audio             --
--   DEFAULT EDID 06 : HDMI 4Kx2K@60/10G, PCM,DTS/DOLBY            --
--   DEFAULT EDID 07 : DVI Video Max. 1280x720@60, No Audio        --
--   DEFAULT EDID 08 : DVI Video Max. 1920x1080@60, No Audio       --
--                                                                    --
-- System Control Setup Commands: ( z=[0~4] )                        --

```

```
-- SPCFB E/D      : Set Front Panel Buttons E/D (E=Enable,D=Disable)  --
-- SPCFD ON/OFF  : Set Front LCD Backlight and LEDs ON/OFF           --
-- SPC RSB z     : Set Main RS232 Baud Rate to z bps, z=[0-4]         --
--                [0:57600, 1:38400, 2:19200, 3:9600, 4:4800]        --
-- SPCDF         : Reset All Settings to Factory Default              --
-- SPCDF 00      : Reset All Settings except of Network/Naming Setting --
-----
```

Status Command (STA). Returns unit status and settings in readable format:

```
-----
--                Key Digital Systems STATUS                          --
-----
-- Model: KD-VW4x4ProK,          Device Name: VW4x4ProK_0001        --
-- Main F/W Ver: 1.00,                                                  --
--                                                                    --
-- RS232 : Baud Rate=57600bps, Data=8bit, Parity=None, Stop=1bit     --
-- Front Panel Button : Enabled                                       --
-- Front LCD Display Backlight : ON                                   --
--                                                                    --
-- Network Setting(Telnet Server) Status                               --
-- MAC Address = 60:89:B1:40:00:01                                    --
-- Host IP Address = 192.168.000.239                                  --
-- Net Mask = 255.255.255.000                                         --
-- Router IP Address = 192.168.000.001                                --
-- TCP Port = 0023                                                    --
--                                                                    --
-- Video Input Status                                                 --
-- 01: EDID = DEFAULT05, Link = ON, VF = 4K, Name = Input 01        --
-- 02: EDID = DEFAULT05, Link = ON, VF = 1080p, Name = Input 02     --
-- 03: EDID = DEFAULT05, Link = ON, VF = 720p, Name = Input 03     --
-- 04: EDID = DEFAULT05, Link = OFF, VF = 480p, Name = Input 04    --
--                                                                    --
-- Video Output Status                                               --
-- 01: Input = 01, Link = ON, PG = 0, HA = ON, Video Format = 4K     --
-- OSD = OFF, Size = 1, XY = (0010,0010), Name = Display 01        --
-----
```

```

-- 01: Input = 02, Link = ON, PG = 0, HA = ON, Video Format = 4K --
-- OSD = OFF, Size = 1, XY = (0010,0010), Name = Display 02 --
-- 01: Input = 03, Link = ON, PG = 0, HA = ON, Video Format = 1080p --
-- OSD = OFF, Size = 1, XY = (0010,0010), Name = Display 03 --
-- 01: Input = 04, Link = ON, PG = 0, HA = ON, Video Format = 720p --
-- OSD = ON , Size = 1, XY = (0010,0010), Name = Display 04 --
-- --
-- External Audio Output Status --
-- 01 : Input = 01, Balanced = Enable, PCM(Coax) = Enable --
-- 02 : Input = 02, Balanced = Enable, PCM(Coax) = Enable --
-- 03 : Input = 03, Balanced = Enable, PCM(Coax) = Enable --
-- 04 : Input = 04, Balanced = Enable, PCM(Coax) = Enable --
-- --
-- External IR In/Out Status --
-- 01 : Serial IR IN --
-- 02 : Serial IR IN --
-- 03 : Serial IR IN --
-- 04 : Serial IR IN --
-- --
-- Video Wall Mode Status --
-- Video Wall = OFF, Mode = 2Hx2V, Input = 01 --
-- 01: Flip = ON, Bezel Left = 00, Right = 00, Top = 00, Bottom = 00 --
-- 02: Flip = ON, Bezel Left = 00, Right = 00, Top = 00, Bottom = 00 --
-- 03: Flip = OFF, Bezel Left = 00, Right = 00, Top = 00, Bottom = 00 --
-- 04: Flip = OFF, Bezel Left = 00, Right = 00, Top = 00, Bottom = 00 --
-----

```

Integrating with AV over IP Systems

If AV over IP decoders feed into KD-VW4x4ProK's HDMI inputs as pictured in the below diagram image jitter may occur. Disable TruMotion features on each display to resolve.

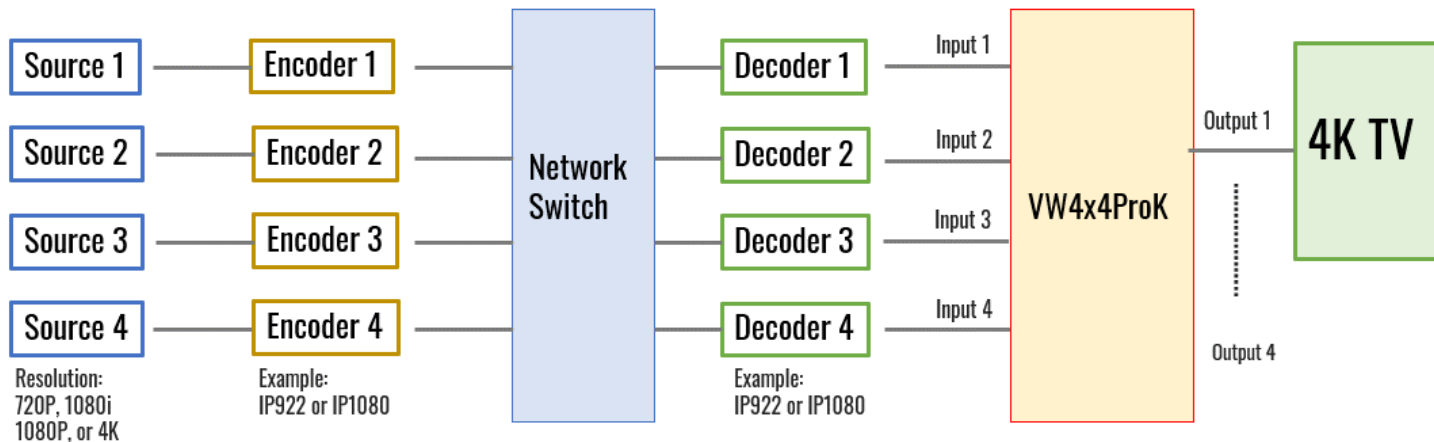

- **LG:** Settings > Picture > Picture Mode Settings > Picture Options > TruMotion > Off

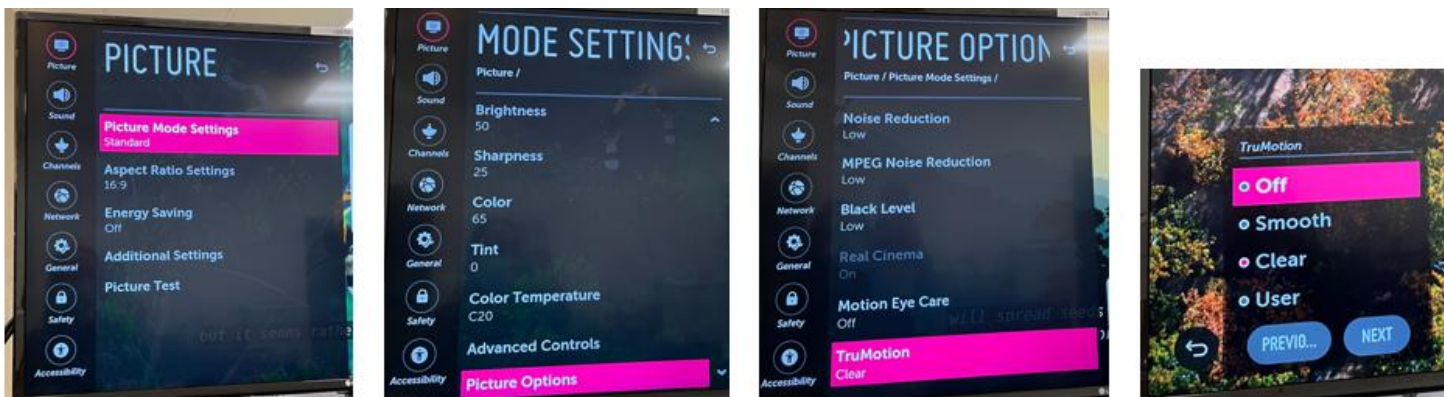

- **Samsung:** Settings > Picture > Expert Settings > Auto Motion Plus Settings > Auto Motion Plus > Off



- **Sony:** Settings > Picture & Display > Picture Adjustment > Advanced Settings > Motion > Motionflow OFF

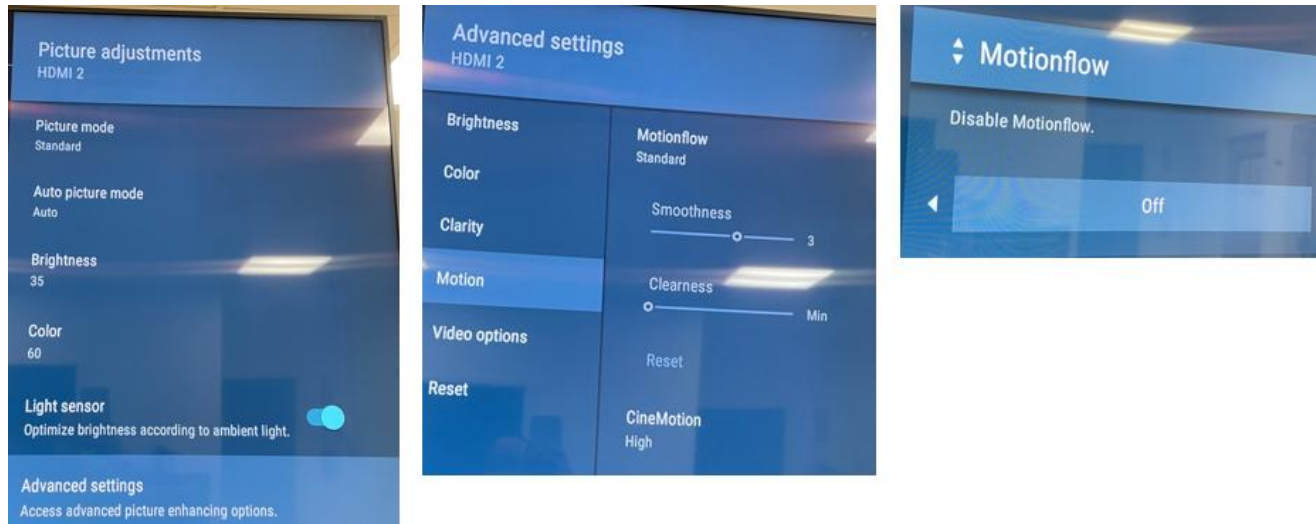

Specifications

Technical

- Input (Each): 1 HDMI Connector, Type A, 19 Pin Female
- Output (Each): 1 HDMI Connector, Type A, 19 Pin Female
- Output (Each): Balanced/unbalanced line level audio on 6-pin terminal block. Drives 2VRMS line audio input with a sampling rate of 192KHz
- Output (each): TOSlink optical digital audio following SPDIF format (IEC 60958). Supports sampling rate up to 192KHz
- Video Bandwidth: TMDS bandwidth 10.2 Gbps
- DDC Signal (Data): Input DDC Signal - 5 Volts p-p (TTL)
- HDMI Video/Audio Signal: Input Video Signal - 1.2 Volts p-p
- DDC Communication: EDID and HDCP Bi-directional buffering to Display and Source
- Analog Audio Max Output Level: 4dBu on 150kΩ, DC coupling
- Audio Bandwidth: 20Hz to 20kHz @ 0dBu
- TND + Noise: 0.33% @0dBu @ 1kHz
- Optical Max Output Level: 1Vpp on 75Ω, DC coupling
- Wired IR: modulated IR signal input, 0-5V TTL or -10 to +10V
- Power: 12V/5 (60W) AC Power Supply with Grounded, 2.1mm ID DC Power Jack with Screw In Type

General

- Regulation: CE, RoHS, WEEE, EAC
- Product Dimensions (LxWxH): 17.24 x 10.78 x 1.73" (438 x 237.7 x 44mm)
- Product Weight: Weight: 8.02 lbs / 3.64 kg
- Packaging Dimensions (LxWxH): 19.69 x 14.72 x 5.12" (500 x 374 x 130mm)
- Packaging Weight: 13.93 lbs / 6.32 kg

Warranty Information

All Key Digital® products are built to high manufacturing standards and should provide years of trouble-free operation. They are backed by a Key Digital Limited 3 Year Product Warranty Policy.

<http://www.keydigital.com/warranty.htm>

Product Warnings & Safety Instructions



Important Product Warnings:

1. Connect all cables before providing power to the unit.
2. Test for proper operation before securing unit behind walls or in hard to access spaces.
3. If installing the unit into wall or mounting bracket into sheet-rock, provide proper screw support with bolts or sheet-rock anchors.



Safety Instructions:

Please be sure to follow these instructions for safe operation of your unit.

1. Read and follow all instructions.
2. Heed all warnings.
3. Do not use this device near water.
4. Clean only with dry cloth.
5. Install in accordance with the manufacturer's instructions.
6. Do not install near any heat sources such as radiators, heat registers, stoves, or other apparatus (including amplifiers) that produce heat.
7. Only use attachments/accessories specified by the manufacturer.
8. Refer all servicing to qualified service personnel. Servicing is required when the device has been damaged in any way including:
 - Damage to the power supply or power plug
 - Exposure to rain or moisture



Power Supply Use:

You MUST use the Power Supply provided with your unit or you VOID the Key Digital® Warranty and risk damage to your unit and associated equipment.

Notes

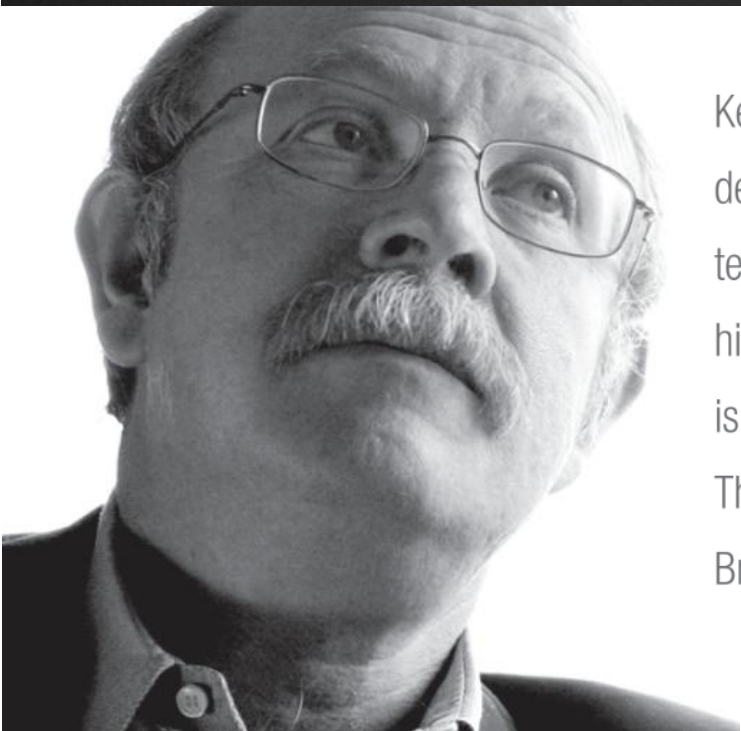

Key Digital[®], led by digital video pioneer Mike Tsinberg, develops and manufactures high quality, cutting-edge technology solutions for virtually all applications where high-end video and control are important. Key Digital[®] is at the forefront of the video industry for Home Theater Retailers, Custom Installers, System Integrators, Broadcasters, Manufacturers, and Consumers.

Key digital[®]
Engineered for Your Success[™]